

BARBEE ST. SUBDIVISION

0 EAST BARBEE STREET

ZEBULON, NORTH CAROLINA

CONSTRUCTION DRAWINGS

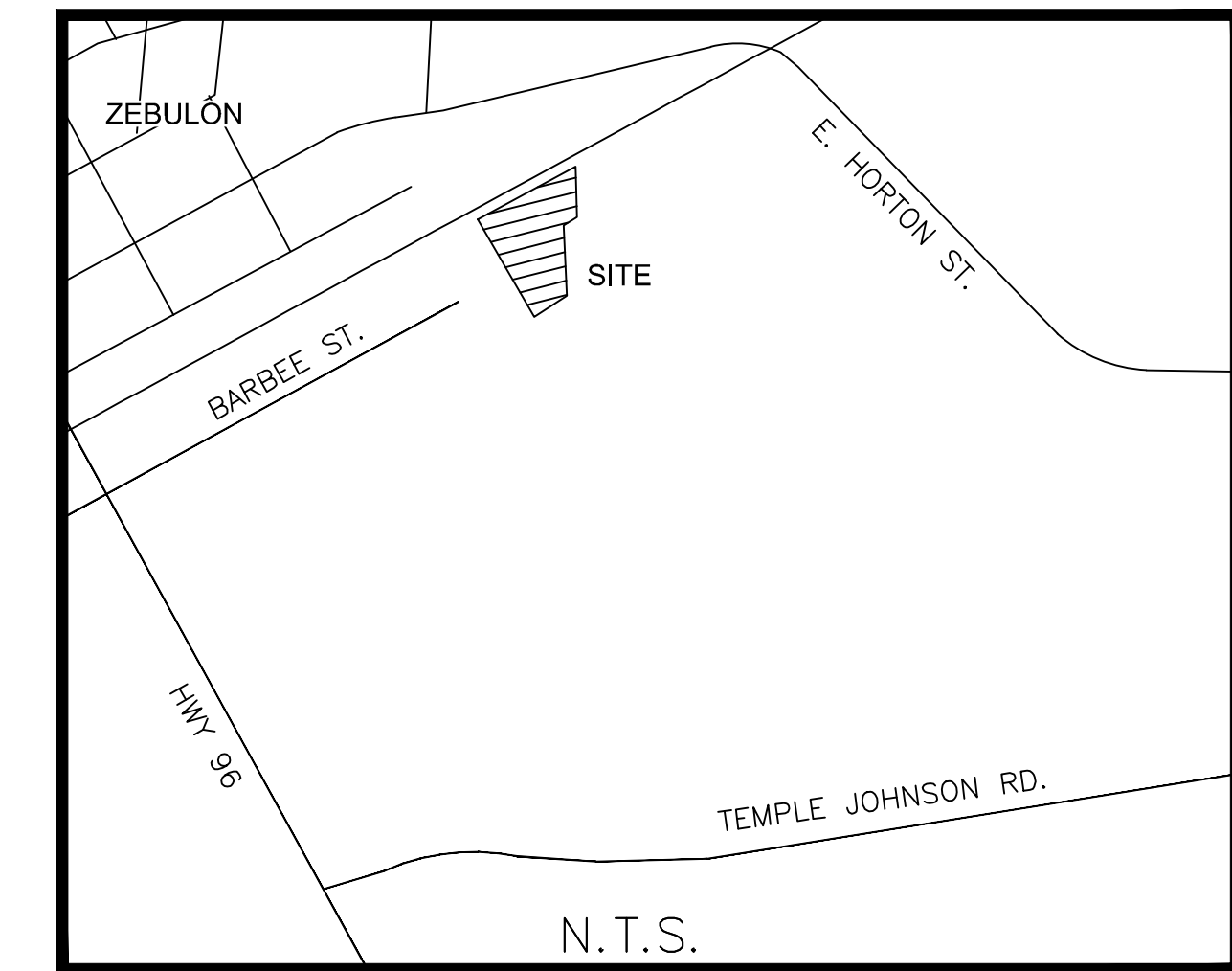

N.T.S.
VICINITY MAP

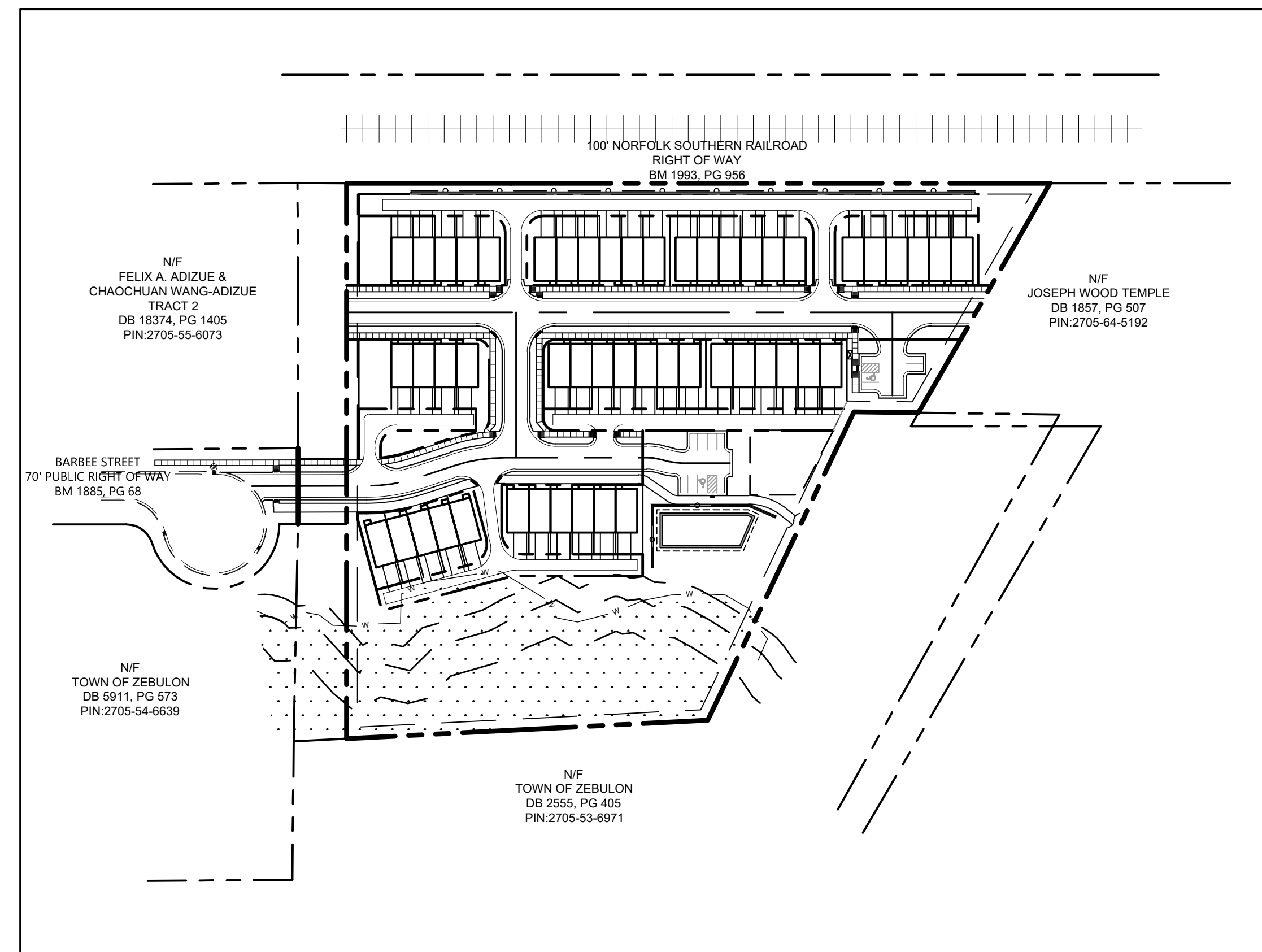

SITE DATA SUMMARY

PROJECT NAME:	2705-65-0231
PIN(S):	2705-65-7077
SITE ADDRESS:	0 E. BARBEE STREET 413 E. BARBEE STREET
JURISDICTION:	WAKE COUNTY
ZONING:	DTP
RIVER BASIN:	NEUSE
TOTAL EXISTING ACREAGE:	246,114 SF / 5.65 ACRES
CURRENT USE:	VACANT
PROPOSED USE:	SINGLE-FAMILY ATTACHED DWELLING
BUILDING SETBACKS:	
STREET:	NONE
SIDE:	5 FT
REAR:	15 FT
TOTAL NUMBER OF UNITS:	53 UNITS
MINIMUM LOT AREA:	3,000 SF
AVERAGE LOT AREA:	
REQUIRED PARKING (2/UNIT+0.25/UNIT):	106 RESIDENT, 13 GUEST
PROVIDED PARKING:	106 RESIDENT, 14 GUEST

GENERAL NOTES

- ALL MATERIALS AND METHODS OF CONSTRUCTION SHALL BE IN ACCORDANCE WITH THE TOWN OF ZEBULON AND THE STATE OF NORTH CAROLINA STANDARDS AND SPECIFICATIONS.
- CONTRACTOR SHALL HAVE NORTH CAROLINA ONE CALL (811) LOCATE ALL EXISTING UTILITIES PRIOR TO BEGINNING CONSTRUCTION.
- CONTRACTOR SHALL VERIFY THE LOCATION AND DEPTH OF ALL EXISTING UTILITIES AND NOTIFY THE ENGINEER OF ANY DISCREPANCIES OR CONFLICTS PRIOR TO BEGINNING CONSTRUCTION.
- BOUNDARY AND SURVEY INFORMATION IS TAKEN FROM A SURVEY BY ANGLE RIGHT LAND SURVEYING, PLLC DATED JUNE 1, 2022.
- ALL CONSTRUCTION SHALL CONFORM TO A.D.A. STANDARDS.
- NO PORTION OF THE PROPERTY IS LOCATED WITHIN A FEMA AE FLOOD ZONE BASED ON THE MAP #3720270500J MAP REVISED MAY 6, 2006.

DRAWINGS INDEX:

SITE 001	COVER SHEET
BD-1	BOUNDARY SURVEY
SITE 100	EXISTING CONDITIONS PLAN
SITE 200	SITE LAYOUT PLAN
SITE 300	GRADING & DRAINAGE PLAN
SITE 301	WET DETENTION POND PLAN
SITE 302	INITIAL EROSION CONTROL PLAN
SITE 303	FINAL EROSION CONTROL PLAN
SITE 304	NPDES PLAN
SITE 400	UTILITY PLAN
SITE 500	LANDSCAPE PLAN
SITE 700	SITE DETAILS
SITE 701	SITE DETAILS
SITE 702	SITE DETAILS
SITE 703	SITE DETAILS
SITE 704	SITE DETAILS
SITE 705	SITE DETAILS
SITE 706	SITE DETAILS
SITE 707	SITE DETAILS
SITE 708	SITE DETAILS

CONTACT/CIVIL ENGINEER:
THE SITE GROUP, PLLC
ATTN: SAMUEL R. NYE, P.E.
1111 OBERLIN ROAD
RALEIGH, NC 27605
PHONE: (919) 835-4787
FAX: (919) 839-2255
EMAIL: srm@thesitegroup.net

CLIENT:
SOCIETY REAL ESTATE, LLC
ATTN: SHERRY CASE
4030 WAKE FOREST RD. STE 100
RALEIGH, NC 27609
PHONE: 910-621-4648
EMAIL: sherry@societyrealttygroup.com

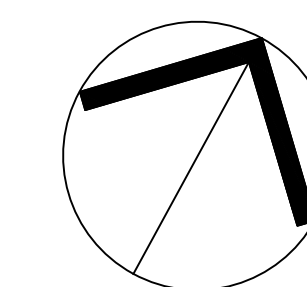

NORTH
COVER SHEET

SCALE: 1" = 100' (DRAWING SCALED FOR 24x36 INCH PLOTS)



FLOODPLAIN NOTE:

THIS SITE IS NOT IN ANY SPECIAL FLOOD HAZARD AREAS OR FUTURE CONDITIONS FLOOD HAZARD AREAS, AS SHOWN ON FIRM PANEL 3720270500K DATED JULY 19, 2022.

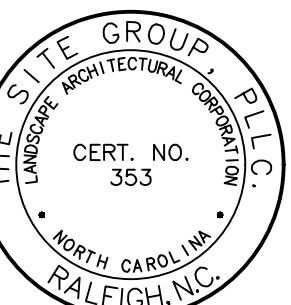

NC ENGINEERING
LICENSE NO. P-0803



PRELIMINARY FOR
REVIEW ONLY

THE SITE GROUP
CIVIL ENGINEERS • LANDSCAPE ARCHITECTS

THE SITE GROUP, PLLC
1111 OBERLIN ROAD
RALEIGH, NC 27605-1136 USA
Office: 919.835.4787
Fax: 919.839.2255
E Mail: srm@thesitegroup.net

CONSTRUCTION DRAWINGS FOR:
BARBEE ST. SUBDIVISION
0 E. BARBEE STREET
ZEBULON, NORTH CAROLINA

Drawn By: **WRR**
Checked By: **SRN**

DATE:
07 NOV 2022

CONSTRUCTION DRAWINGS

COVER SHEET

Job Code: **SCBSZ**

Dwg No.
SITE 001

Copyright © 2022 The Site Group, PLLC. ALL RIGHTS RESERVED.

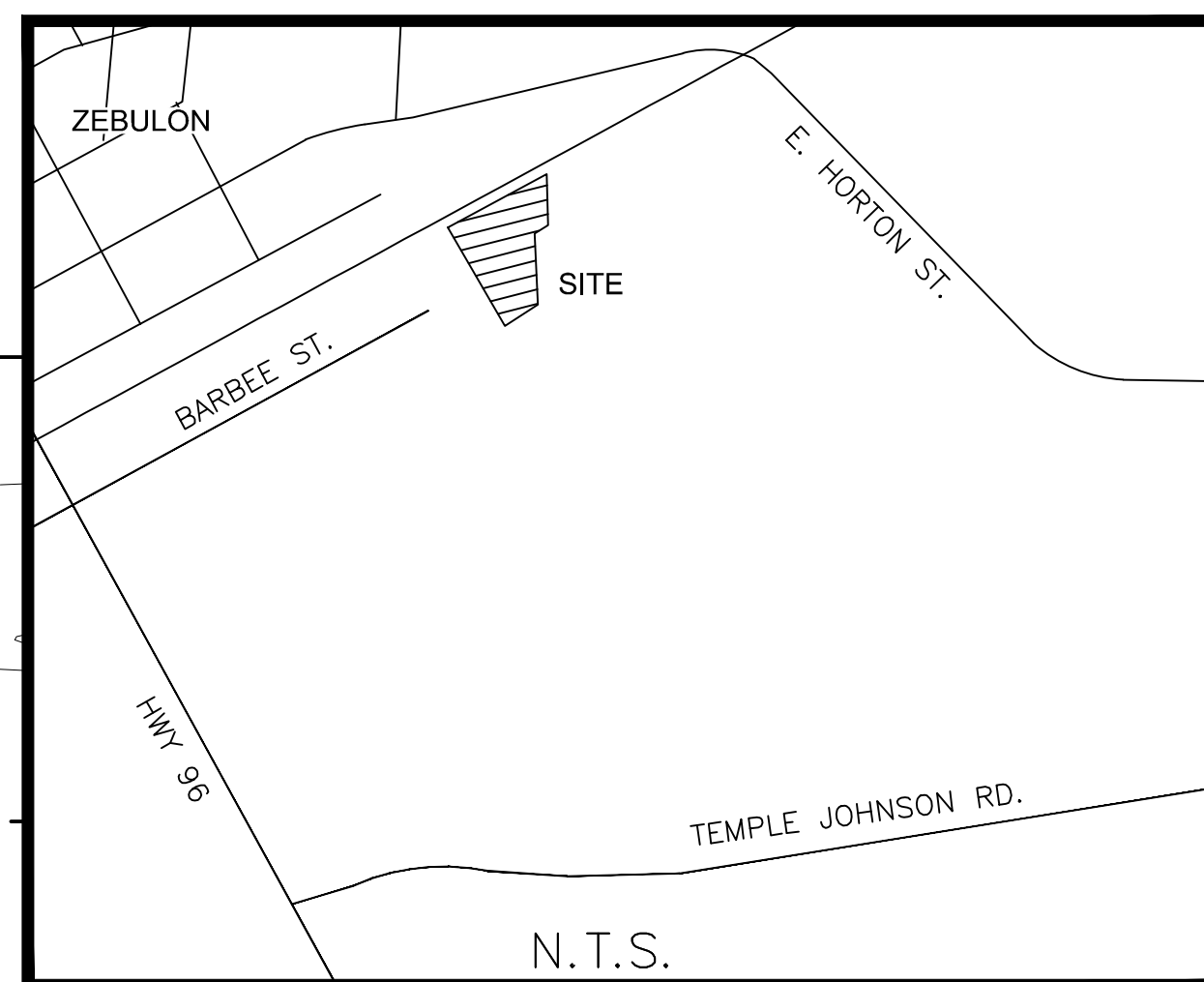
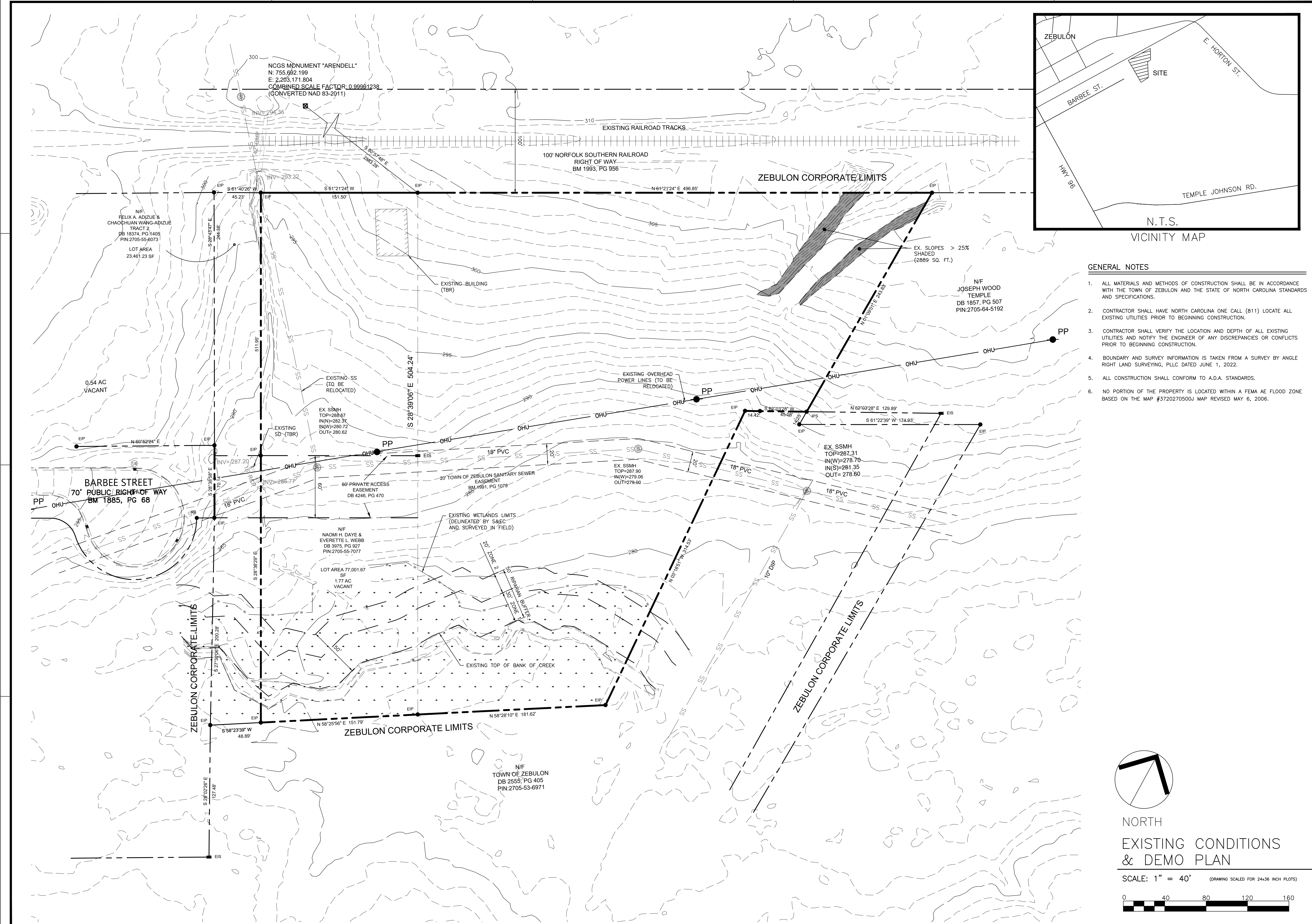

GENERAL NOTES

1. ALL MATERIALS AND METHODS OF CONSTRUCTION SHALL BE IN ACCORDANCE WITH THE TOWN OF ZEBULON AND THE STATE OF NORTH CAROLINA STANDARDS AND SPECIFICATIONS.
2. CONTRACTOR SHALL HAVE NORTH CAROLINA ONE CALL (811) LOCATE ALL EXISTING UTILITIES PRIOR TO BEGINNING CONSTRUCTION.
3. CONTRACTOR SHALL VERIFY THE LOCATION AND DEPTH OF ALL EXISTING UTILITIES AND NOTIFY THE ENGINEER OF ANY DISCREPANCIES OR CONFLICTS PRIOR TO BEGINNING CONSTRUCTION.
4. BOUNDARY AND SURVEY INFORMATION IS TAKEN FROM A SURVEY BY ANGLE RIGHT LAND SURVEYING, PLLC DATED JUNE 1, 2022.
5. ALL CONSTRUCTION SHALL CONFORM TO A.D.A. STANDARDS.
6. NO PORTION OF THE PROPERTY IS LOCATED WITHIN A FEMA AE FLOOD ZONE BASED ON THE MAP #3720270500J MAP REVISED MAY 6, 2006.

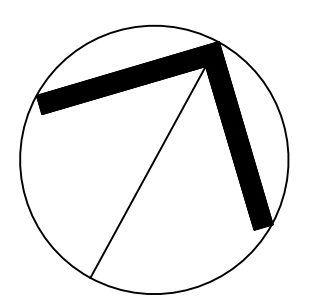

NORTH
 EXISTING CONDITIONS
 & DEMO PLAN

SCALE: 1" = 40' (DRAWING SCALED FOR 24x36 INCH PLOTS)

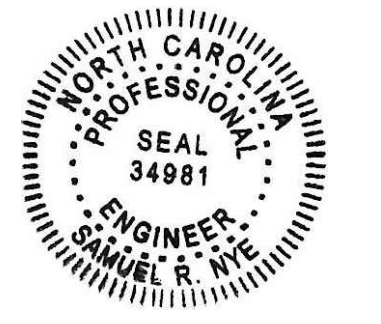
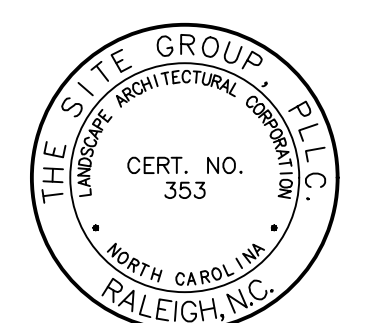

PRELIMINARY FOR REVIEW ONLY

THE SITE GROUP
 CIVIL ENGINEERS • LANDSCAPE ARCHITECTS
 THE SITE GROUP, PLLC
 111 S. OGDEN ST., SUITE 200
 RALEIGH, NC 27605-1136 USA
 Office: 919.835.4787
 Fax: 919.839.2255
 E-Mail: SRN@thesitegroup.net

CONSTRUCTION DRAWINGS FOR:
BARBEE ST. SUBDIVISION
 0 E. BARBEE STREET
 ZEBULON, NORTH CAROLINA

Drawn By: **WRR**
 Checked By: **SRN**

DATE:
 07 NOV 2022

CONSTRUCTION DRAWINGS

EXISTING CONDITIONS & DEMO PLAN

Job Code: **SCBSZ**

Dwg No.
SITE 100

Copyright © 2022 The Site Group, PLLC. ALL RIGHTS RESERVED.

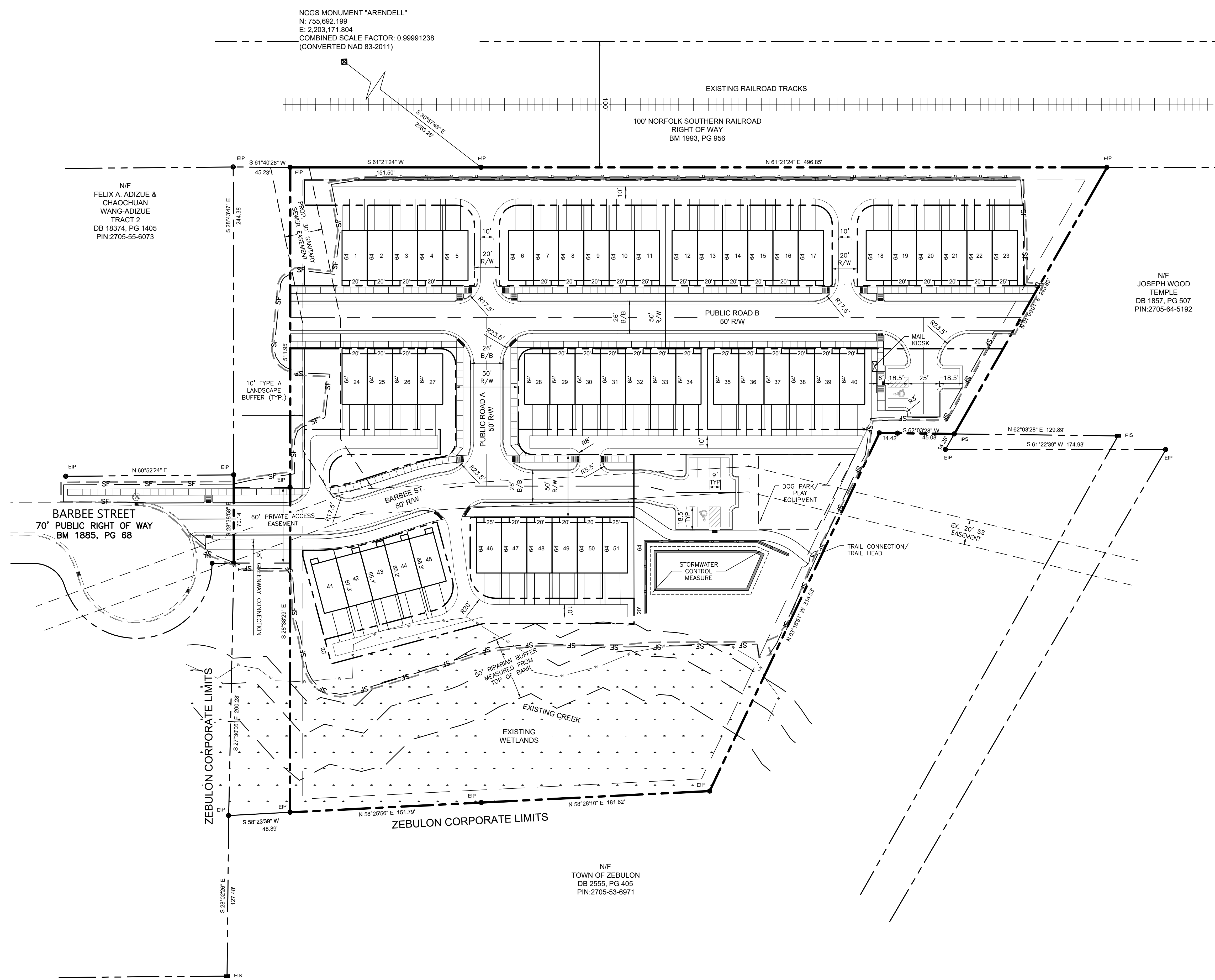

SITE DATA SUMMARY

PROJECT NAME:	2705-65-0231
PIN(S):	2705-55-7077
SITE ADDRESS:	0 E BARBEE STREET 413 E BARBEE STREET
JURISDICTION:	WAKE COUNTY
ZONING:	DTP
RIVER BASIN:	NEUSE
TOTAL EXISTING ACREAGE:	246,114 SF / 5.65 ACRES
CURRENT USE:	VACANT
PROPOSED USE:	SINGLE-FAMILY ATTACHED DWELLING
BUILDING SETBACKS:	
STREET:	NONE
SIDE:	5 FT
REAR:	15 FT
TOTAL NUMBER OF UNITS:	53 UNITS
MINIMUM LOT AREA:	3,000 SF
AVERAGE LOT AREA:	
REQUIRED PARKING (2/UNIT+0.25/UNIT):	106 RESIDENT, 13 GUEST
PROVIDED PARKING:	106 RESIDENT, 14 GUEST

- ### GENERAL NOTES
- ALL MATERIALS AND METHODS OF CONSTRUCTION SHALL BE IN ACCORDANCE WITH THE TOWN OF ZEBULON AND THE STATE OF NORTH CAROLINA STANDARDS AND SPECIFICATIONS.
 - CONTRACTOR SHALL HAVE NORTH CAROLINA ONE CALL (811) LOCATE ALL EXISTING UTILITIES PRIOR TO BEGINNING CONSTRUCTION.
 - CONTRACTOR SHALL VERIFY THE LOCATION AND DEPTH OF ALL EXISTING UTILITIES AND NOTIFY THE ENGINEER OF ANY DISCREPANCIES OR CONFLICTS PRIOR TO BEGINNING CONSTRUCTION.
 - BOUNDARY AND SURVEY INFORMATION IS TAKEN FROM A SURVEY BY ANGLE RIGHT LAND SURVEYING, PLLC DATED JUNE 1, 2022.
 - ALL CONSTRUCTION SHALL CONFORM TO A.D.A. STANDARDS.
 - NO PORTION OF THE PROPERTY IS LOCATED WITHIN A FEMA AE FLOOD ZONE BASED ON THE MAP #3720270500J MAP REVISED MAY 6, 2006.

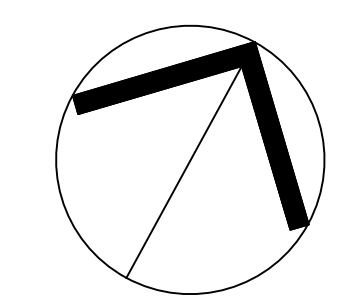

NORTH
SUBDIVISION
LAYOUT PLAN

SCALE: 1" = 40' (DRAWING SCALED FOR 24x36 INCH PLOTS)

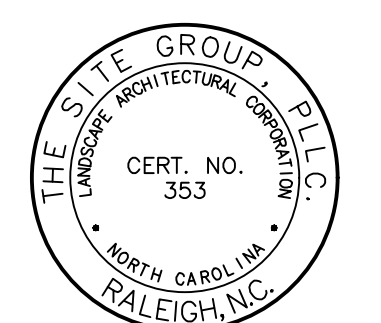
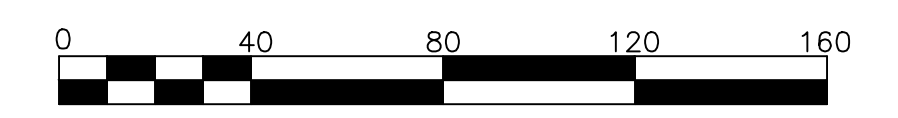

NO ENGINEERING LICENSE NO. P-0803



PRELIMINARY FOR REVIEW ONLY

THE SITE GROUP
CIVIL ENGINEERS • LANDSCAPE ARCHITECTS
THE SITE GROUP, PLLC
111 S. COLEMAN ST.
RALEIGH, NC 27605-1136 USA
Office: 919.835.4787
Fax: 919.839.2255
E Mail: SRN@thesitegroup.net

CONSTRUCTION DRAWINGS FOR:
BARBEE ST. SUBDIVISION
0 E BARBEE STREET
ZEBULON, NORTH CAROLINA

Drawn By: **WRR**
Checked By: **SRN**

DATE:
07 NOV 2022

CONSTRUCTION DRAWINGS

SUBDIVISION LAYOUT PLAN

Job Code: **SCBSZ**

Dwg No.
SITE 200

NGCS MONUMENT "ARENDELL"
 N: 755,892.199
 E: 2,203,171.804
 COMBINED SCALE FACTOR:
 0.99991238
 (CONVERTED NAD 83-2011)

N/F
 FELIX A. ADIZUE &
 CHAOCHUAN
 WANG-ADIZUE
 TRACT 2
 DB 18374, PG 1405
 PIN:2705-55-6073

N/F
 JOSEPH WOOD
 TEMPLE
 DB 1857, PG 507
 PIN:2705-64-5192

BARBEE STREET
 70' PUBLIC
 RIGHT OF WAY
 BM 1885, PG 68

N/F
 TOWN OF ZEBULON
 DB 2555, PG 405
 PIN:2705-53-6971

GRADING NOTES:

1. ALL CONSTRUCTION SHALL COMPLY WITH TOWN OF ZEBULON STANDARDS AND SPECIFICATIONS.
2. THE CONTRACTOR SHALL BE RESPONSIBLE FOR CONTACTING, COORDINATING, AND PAYMENT FOR ALL NECESSARY LOCATING SERVICES INCLUDING INDEPENDENT LOCATING SERVICES. THE CONTRACTOR SHALL HAVE ALL EXISTING UTILITIES LOCATED AT LEAST 48 HOURS PRIOR TO BEGINNING DEMOLITION, EXCAVATION, OR ANY OTHER FORM OF CONSTRUCTION. THE CONTRACTOR SHALL IMMEDIATELY NOTIFY THE OWNER'S REPRESENTATIVE OF ANY DISCREPANCIES OR CONFLICTS.
3. EXISTING IMPROVEMENTS DAMAGED OR DESTROYED BY THE CONTRACTOR DURING CONSTRUCTION SHALL BE RESTORED OR REPLACED TO ORIGINAL CONDITION AND TO THE SATISFACTION OF THE OWNER'S REPRESENTATIVE AT THE CONTRACTOR'S EXPENSE.
4. THE CONTRACTOR SHALL BE RESPONSIBLE FOR ENSURING ALL PERMITS, INSPECTIONS, CERTIFICATIONS, AND OTHER REQUIREMENTS WHICH MUST BE MET UNDER THIS CONTRACT ARE OBTAINED.
5. IF DEPARTURES FROM THE PROJECT DRAWINGS OR SPECIFICATIONS ARE DEEMED NECESSARY BY THE CONTRACTOR, DETAILS OF SUCH DEPARTURES AND REASONS THEREFORE SHALL BE SUBMITTED TO THE OWNER'S REPRESENTATIVE FOR REVIEW PRIOR TO CONSTRUCTION. NO DEPARTURES FROM THE CONTRACT DOCUMENTS SHALL BE MADE WITHOUT THE EXPRESS WRITTEN PERMISSION OF THE OWNER'S REPRESENTATIVE.
6. THE ENGINEER DISCLAIMS ANY ROLE IN THE CONSTRUCTION MEANS AND/OR METHODS ASSOCIATED WITH THE PROJECT AS SET FORTH IN THESE PLANS.
7. TO MINIMIZE DAMAGE TO EXISTING TREES NEAR THE INTERIOR EDGE OF BUFFERS AND STREETSCAPES, THE CONTRACTOR SHALL CUT MIN. 2" TRENCHES ALONG THE LIMITS OF DISTURBANCE, SO AS TO CUT RATHER THAN TEAR, THE TREE ROOTS. THE TREE PROTECTION FENCE SHALL BE MAINTAINED ON THE SITE UNTIL ALL THE SITE WORK IS COMPLETED AND THE FINAL SITE INSPECTION PRIOR TO CERTIFICATE OF OCCUPANCY(CO) IS SCHEDULED. THE FENCING SHALL BE REMOVED PRIOR TO FINAL SITE INSPECTION FOR THE CO.
8. ALL STORM DRAIN FRAMES GRATES & HOODS SHALL BE STAMPED WITH "DRAINS TO RIVER" IN ACCORDANCE WITH TOWN OF ZEBULON STANDARDS.
9. ALL RISER STRUCTURES AND BARRELS MUST BE ON SITE BEFORE THE GRADING PERMIT IS ISSUED.
10. THIS PROJECT MAY REQUIRE A PRE-CONSTRUCTION CONFERENCE BEFORE THE GRADING PERMIT IS ISSUED.
11. ALL CUT AND FILL SLOPE THAT IS (2:1) OR GREATER SHALL BE STABILIZED WITH PERMANENT SLOPE RETENTION DEVICES OR A SUITABLE COMBINATION OF PLANTINGS AND RETENTION DEVICES. SLOPES GREATER THAN THREE TO ONE (3:1) SHALL NOT BE STABILIZED WITH TURF GRASS BUT MUST BE STABILIZED WITH VEGETATION THAT REQUIRES MINIMAL MAINTENANCE. WEEPING LOVE GRASS, RED FESCUE OR OTHER APPROVED VARIETY. (CHAPTER 7, PART 2, SECTION 4, (G) LDO).
12. THE ESTABLISHMENT OF PERMANENT GROUND COVER WILL BE ESTABLISHED IN 15 WORKING DAYS OR 90 CALENDAR DAYS, WHICHEVER IS SHORTER. THE SITE SHALL BE STABILIZED AND SEEDING PRIOR TO THE ISSUANCE OF A CERTIFICATE OF OCCUPANCY (CO).
13. THE TREE PROTECTION FENCING ON THIS PROJECT WILL BE INSTALLED AND INSPECTED BEFORE THE GRADING PERMIT IS ISSUED. THE TREE PROTECTION FENCE SHALL BE MAINTAINED ON THE SITE UNTIL ALL SITE WORK IS COMPLETED AND THE FINAL SITE INSPECTION IS SCHEDULED PRIOR TO THE ISSUANCE OF A CERTIFICATE OF OCCUPANCY (CO). THE FENCING SHALL BE REMOVED IMMEDIATELY PRIOR TO THE FINAL SITE INSPECTION FOR THE SITE.
14. THE PROJECT WILL MEET ALL OF THE REQUIREMENTS RELATIVE TO BEST MANAGEMENT PRACTICES AND ENGINEERED STORMWATER CONTROL STRUCTURES AS OUTLINED IN THE TOWN OF ZEBULON LAND DEVELOPMENT ORDINANCE. (CHAPTER 4, PART 4.6, LDO).
15. ALL LEVEL SPREADERS ON THE PROJECT MUST BE LOCATED ON COMMON OPEN SPACE, HAVE AN ACCESS AND MAINTENANCE EASEMENTS LOCATED AROUND THEM AND INCLUDE AN OPERATIONS AND MAINTENANCE MANUAL AND A MAINTENANCE AGREEMENT.
16. NO TIEBACKS FOR RETAINING WALLS WILL BE ALLOWED TO ENCROACH INTO THE CITY OF RALEIGH PUBLIC UTILITY EASEMENT.
17. RETAINING WALLS WILL REQUIRE A SEPARATE PERMIT FROM THE TOWN OF ZEBULON INSPECTIONS AND PERMITS DEPARTMENT.
18. THE TREE PROTECTION FENCE SHALL BE MAINTAINED ON THE SITE UNTIL ALL SITE WORK IS COMPLETED AND THE FINAL SITE INSPECTION IS SCHEDULED PRIOR TO THE ISSUANCE OF A CERTIFICATE OF OCCUPANCY. THE FENCING SHALL BE REMOVED IMMEDIATELY PRIOR TO THE FINAL SITE INSPECTION FOR THE SITE.
19. THE SITE SHALL BE STABILIZED AND SEEDING PRIOR TO THE ISSUANCE OF A CERTIFICATE OF OCCUPANCY. (CO)
20. CURB INLET RIM ELEVATIONS REFER TO FLOW LINE. ADD 6" FOR TOP OF CURB ELEVATION.
21. ALL STORM DRAIN FRAMES, GRATES AND HOODS SHALL BE STAMPED WITH "DRAINS TO RIVER" IN ACCORDANCE WITH TOWN OF ZEBULON STANDARDS.
22. RISER STRUCTURES AND BARRELS MUST BE ON SITE BEFORE THE GRADING PERMIT IS ISSUED.

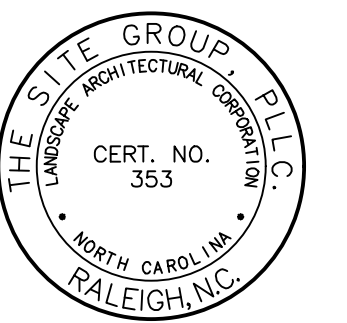

NC ENGINEERING
 LICENSE NO. P-0803

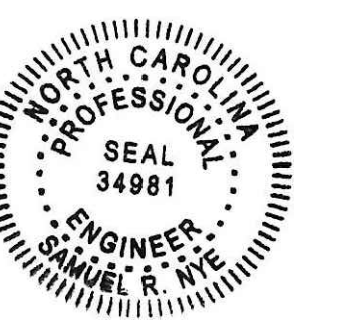

PRELIMINARY FOR
 REVIEW ONLY

THE SITE GROUP
 CIVIL ENGINEERS • LANDSCAPE ARCHITECTS
 THE SITE GROUP, P.L.L.C.
 1110 N. W. 11th St., Suite 27605-1136 USA
 Raleigh, NC 27605-1136
 Office: 919.835.4787
 Fax: 919.839.2255
 E-Mail: SRM@thesitegroup.net

CONSTRUCTION DRAWINGS FOR:
BARBEE ST. SUBDIVISION
 0 E. BARBEE STREET
 ZEBULON, NORTH CAROLINA

Drawn By: **WRR**
 Checked By: **SRN**

DATE:
 07 NOV 2022

CONSTRUCTION
 DRAWINGS

GRADING
 PLAN

Job Code: **SCBSZ**

Dwg No.
**SITE
 300**

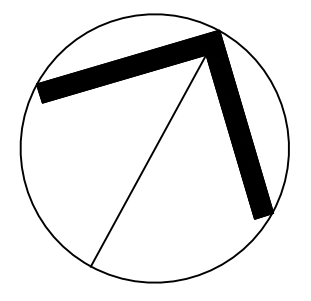

NORTH
 GRADING
 PLAN

SCALE: 1" = 40' (DRAWING SCALED FOR 24x36 INCH PLOTS)

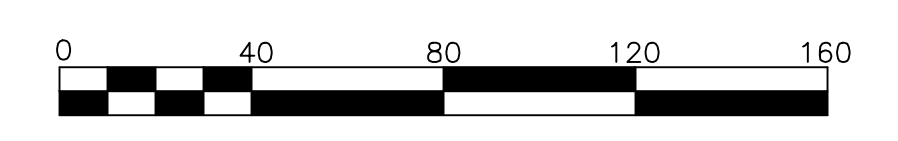

DISTURBED AREA
 194,349 SF / 4.46 AC

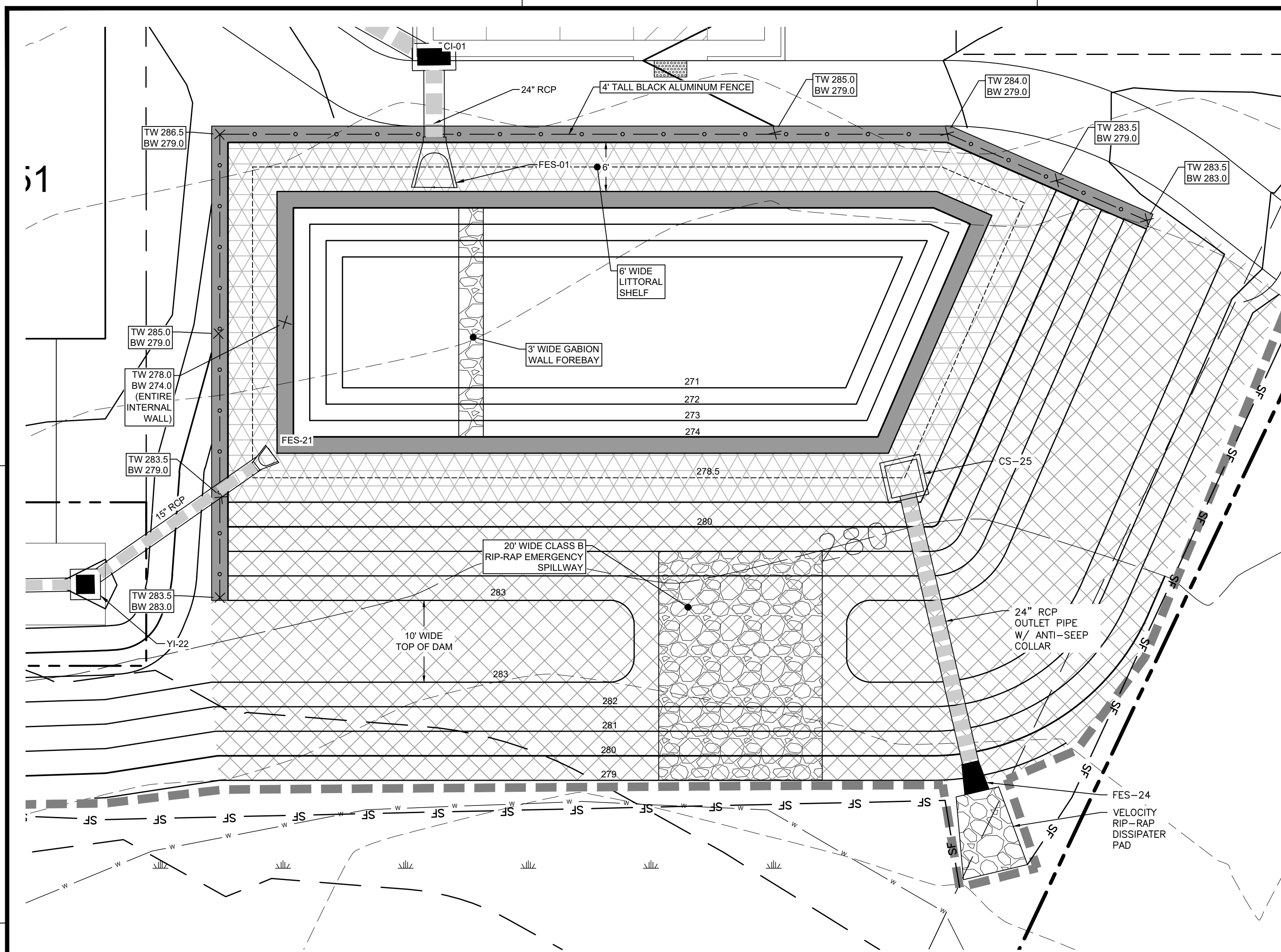

WET POND PLANT LIST

KEY	QTY	BOTANICAL NAME	COMMON NAME	REMARKS
WET POND LITTORAL SHELF - 1,498 SF / 200 x 50 = 374 PLUGS REQUIRED				
CT	93	Carex tenera*	Quill Sedge	3" x 2.5" SQUARE PLUGS (MIN)
EM	93	Eupatoriadelphus maculatus	Spotted trumpetweed	3" x 2.5" SQUARE PLUGS (MIN)
PV	94	Peltandra virginica	Arrow arum	3" x 2.5" SQUARE PLUGS (MIN)
SA	94	Schoenoplectus americanus	Three-square bulrush	3" x 2.5" SQUARE PLUGS (MIN)
SLOPE STABILIZATION GRASSES				
CENTIPEDE GRASS	4,882 SF	Eremochloa ophiuroides		SEED AT 50 LBS. PER ACRE

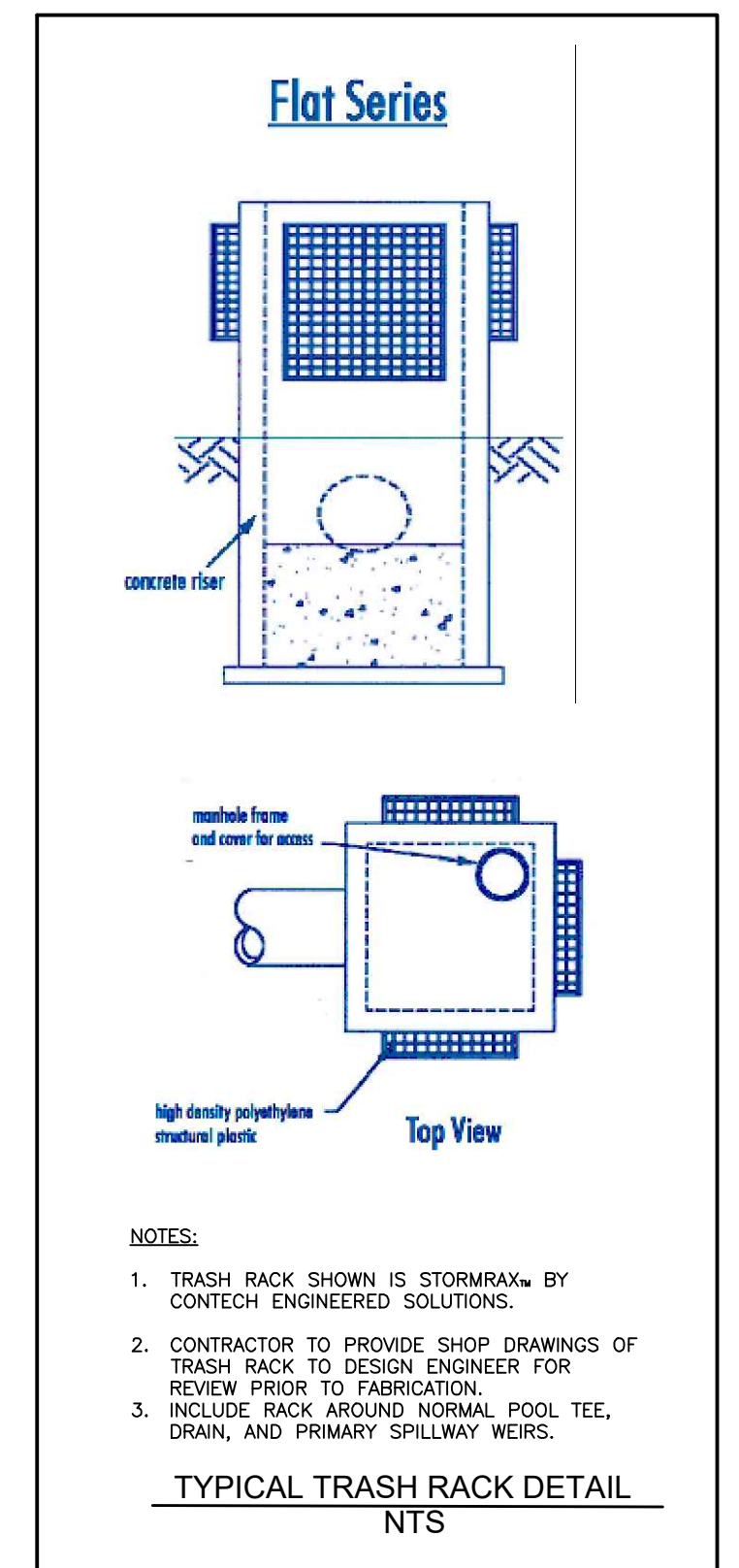
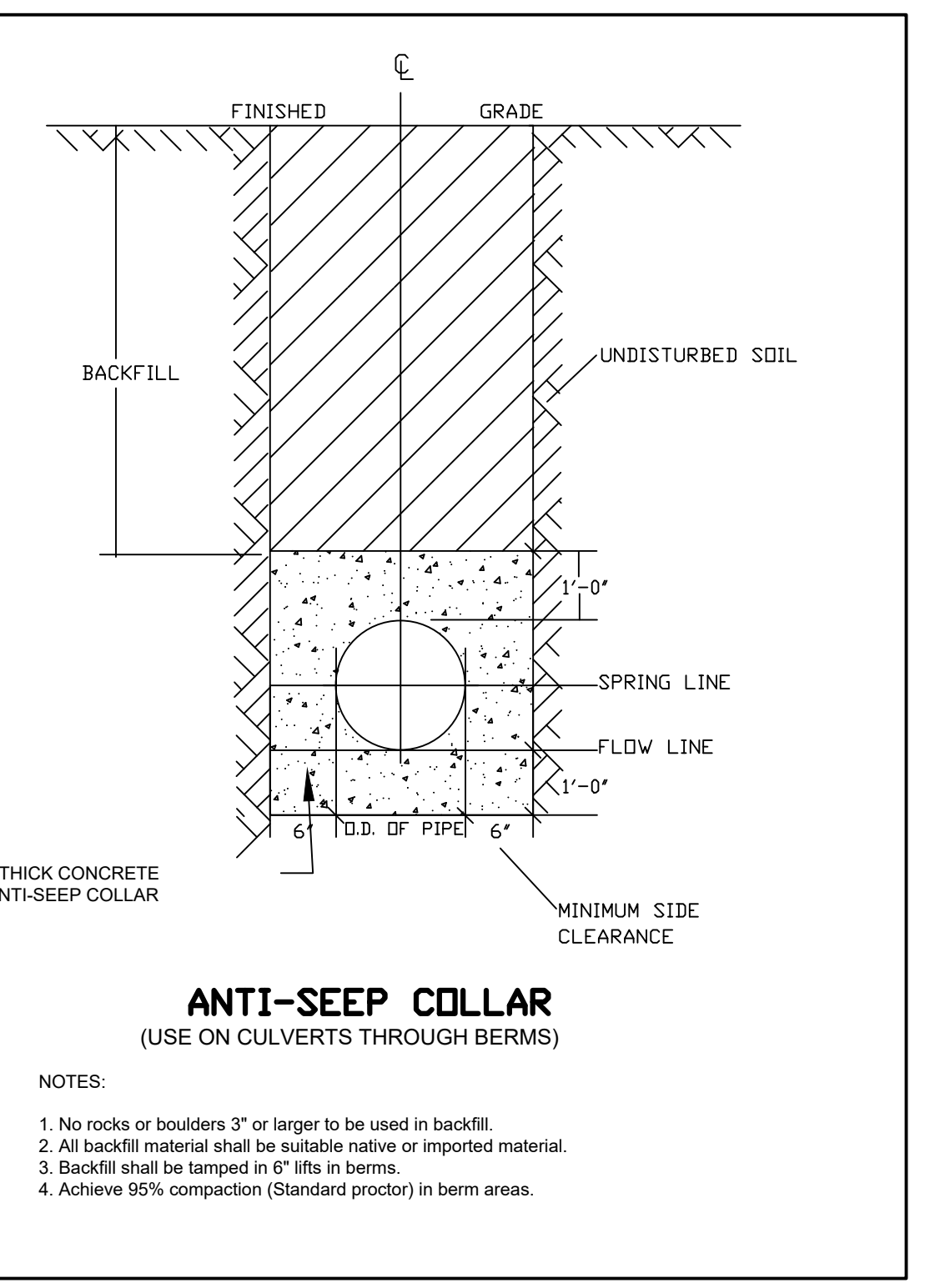
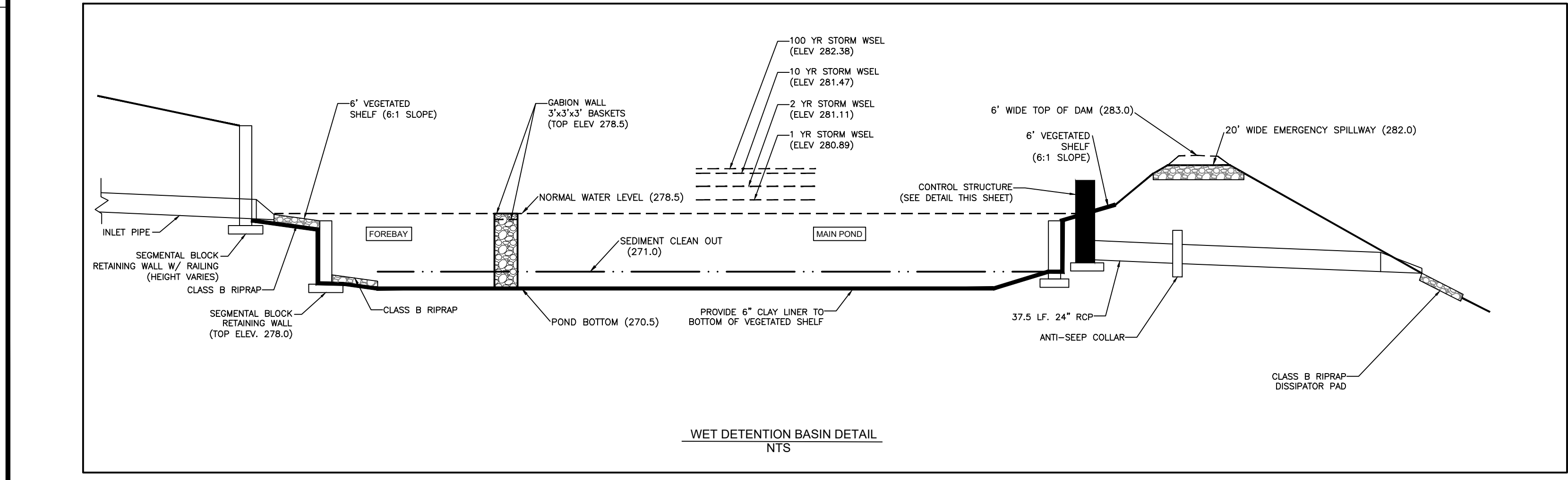
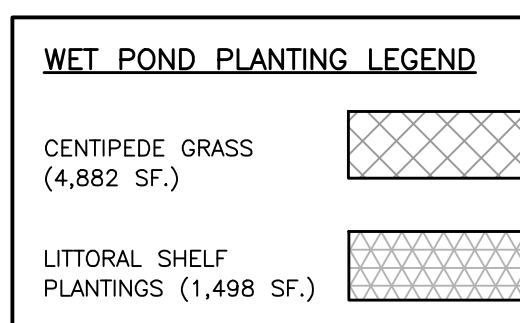
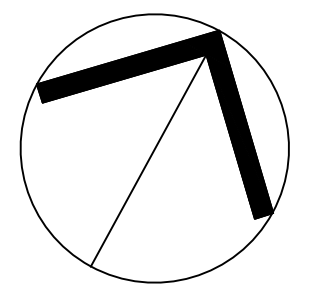
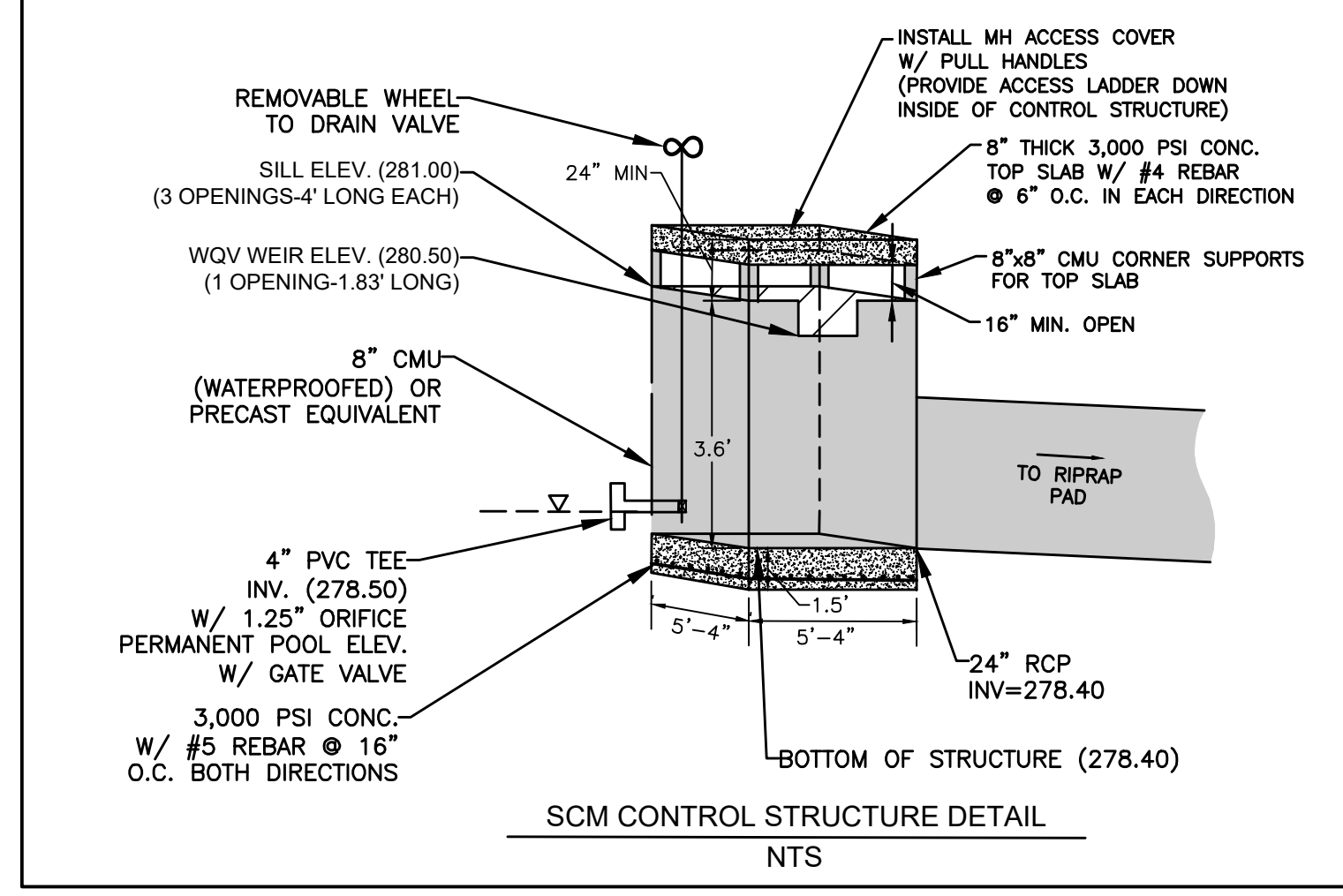
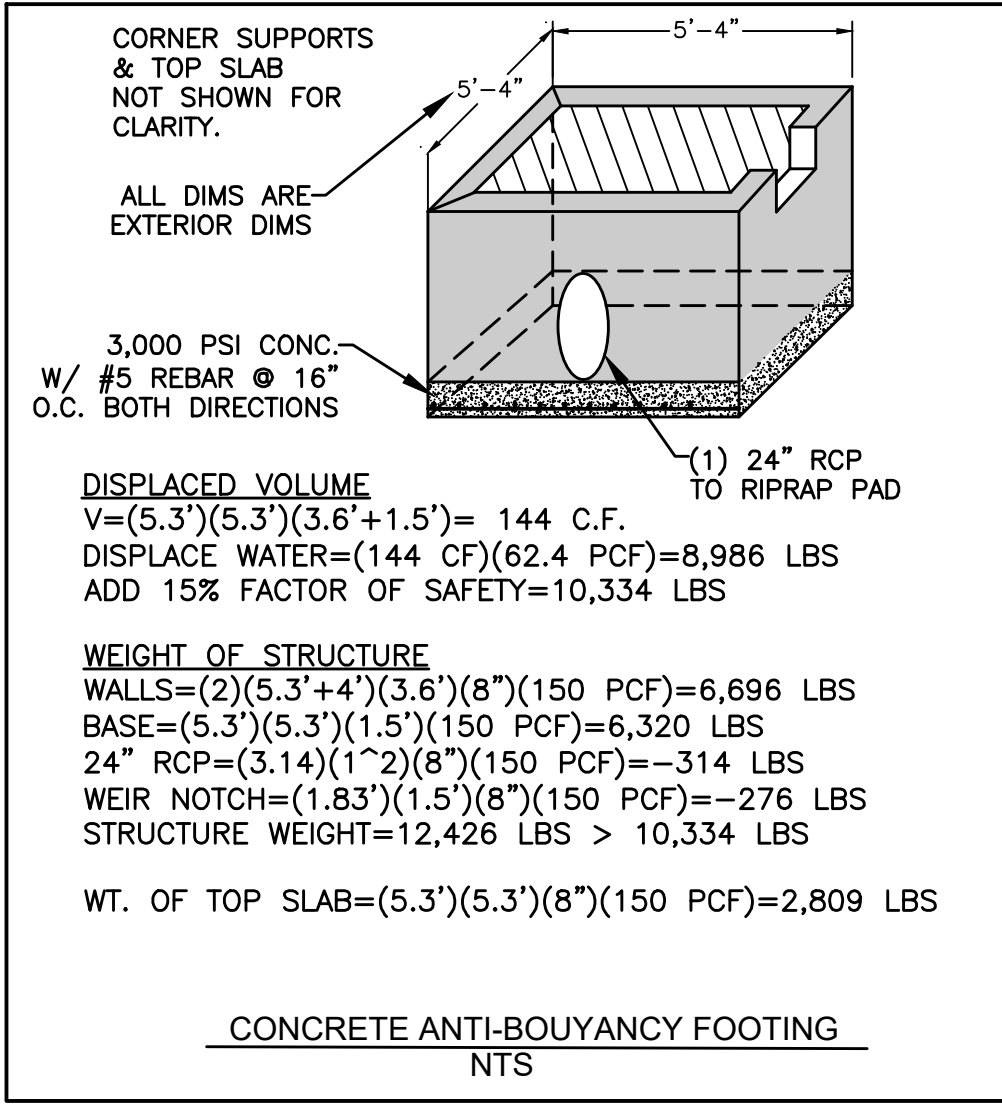

Table 1: Clay Liner Specifications (Source: VADCR, 1999).

Property	Test Method	Unit	Specification
Permeability	ASTM D-2434	Cm/sec	1 x 10 ⁻⁶
Plasticity Index of Clay	ASTM D-423/424	%	Not less than 15
Liquid Limit of Clay	ASTM D-2216	%	Not less than 30
Clay Particles Passing	ASTM D-422	%	Not less than 30
Clay Compaction	ASTM D-2216	%	95% of standard proctor density

GRADING CONTRACTOR MUST DOCUMENT CLAY LINER AND VERIFY MATERIAL WITH GEOTECHNICAL ENGINEER DURING CONSTRUCTION TO ENSURE POND HOLDS WATER. STRUCTURAL ENGINEER FOR RETAINING WALLS AND GEOTECHNICAL ENGINEER TO DESIGN CLAY LINER LOCATION SUCH THAT SEGMENTAL WALL BACKFILL DOES NOT DRAIN POND.

- SCM CONSTRUCTION NOTES:**
- ALL CONSTRUCTION SHALL BE IN ACCORDANCE WITH TOWN OF ZEBULON AND THE STATE OF NORTH CAROLINA STANDARDS AND SPECIFICATIONS.
 - THE PROJECT WILL MEET ALL REQUIREMENTS RELATIVE TO BEST MANAGEMENT PRACTICES AND ENGINEERED STORMWATER CONTROL STRUCTURES AS OUTLINED IN THE NCWQM BMP MANUAL.
 - THE CONTRACTOR SHALL WARRANTY ALL PLANTED MATERIALS FOR A PERIOD OF 2 YEARS FROM DATE OF INSTALLATION. AT THE END OF THE FIRST YEAR AND AT THE END OF THE SECOND YEAR, THE CONTRACTOR SHALL REPLACE ALL PLANTS WHICH DO NOT SURVIVE, ANY HEALTHY PLANTS DAMAGED DURING PLANT REPLACEMENT SHALL ALSO BE REPLACED.
 - SOIL BELOW ELEVATION 345.00 SHALL BE TESTED BY THE USDA AGRICULTURAL EXTENSION OFFICE FOR pH, WHICH MUST FALL BETWEEN 5.5 AND 7.0. TESTS SHALL ALSO BE PERFORMED FOR NUTRIENTS SUCH AS NITROGEN, PHOSPHORUS, AND POTASSIUM, AND FOR MINERALS SUCH AS CHELATED IRON AND LIME. AMENDMENTS TO SOIL RECOMMENDED BY USDA SHALL BE INCORPORATED INTO SOIL TO PROMOTE VIGOROUS VEGETATION AND PLANT GROWTH. RECORDS OF TESTS AND AMENDMENTS PROVIDED BY CONTRACTOR SHALL BE PROVIDED TO THE ENGINEER.
 - LANDSCAPING PLANTINGS SHOWN HEREON SHALL BE INSTALLED DURING FALL SEASON OR EARLY WINTER IF POSSIBLE FOR MAXIMUM PLANT SURVIVABILITY.
 - THE CONTRACTOR OR OWNER SHALL EMPLOY A GEOTECHNICAL ENGINEER TO TEST ALL EMBANKMENTS AND FILL PLACEMENT FOR PROPER COMPACTION. PROPER COMPACTION SHALL BE PER THE GEOTECHNICAL ENGINEER'S RECOMMENDATIONS OF THESE PLANS, WHICHEVER IS MORE STRINGENT. EMBANKMENTS FOR BASINS SHALL BE PLACED IN 6 INCH LOOSE LAYERS AND SHALL BE COMPACTED TO A DENSITY OF NO LESS THAN 95% OF THE STANDARD PROCTOR MAXIMUM DENSITY AT A MOISTURE CONTENT OF + OR - TWO PERCENTAGE POINTS OF THE OPTIMUM MOISTURE CONTENT IN ACCORDANCE WITH ASTM D698. THE CONTRACTOR SHALL TAKE PHOTOGRAPHS OF THE OUTLET STRUCTURE AT ALL PHASES OF INSTALLATION AND SHALL RETAIN WITH GEOTECHNICAL TESTING DATA. THE CONTRACTOR SHALL ALSO RETAIN ALL SHIPPING RECORDS AND SPECIFICATIONS FOR THE OUTLET STRUCTURE MATERIALS AND STRUCTURES. ALL OF THE ABOVE DATA BE REQUIRED AS PART OF THE MUNICIPALITY AS-BUILT PROCESS AND SHALL BE MADE AVAILABLE TO THE ENGINEER UPON REQUEST. THE CONTRACTOR AND OWNER SHALL HAVE DOCUMENTATION OF THESE TESTS AVAILABLE UPON REQUEST.



NORTH
SCM PLAN

SCALE: 1" = 10' (DRAWING SCALED FOR 24x36 INCH PLOTS)

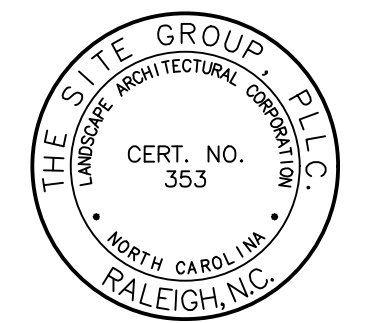
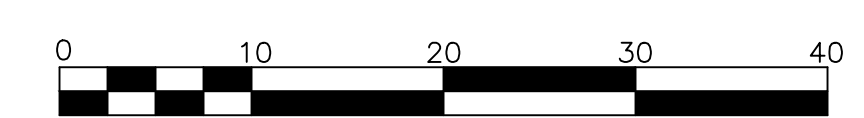

NC ENGINEERING LICENSE NO. P-0803

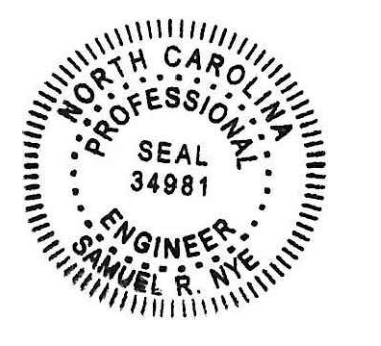

PRELIMINARY FOR REVIEW ONLY

THE SITE GROUP
 CIVIL ENGINEERS • LANDSCAPE ARCHITECTS
 THE SITE GROUP, P.L.L.C.
 1110 W. PINE ST. #200
 RALEIGH, NC 27605-1136 USA
 Office: 919.835.4787
 Fax: 919.839.2255
 E-Mail: SRN@thesitegroup.net

CONSTRUCTION DRAWINGS FOR:
BARBEE ST. SUBDIVISION
 0 E. BARBEE STREET
 ZEBULON, NORTH CAROLINA

Drawn By: WRR
 Checked By: SRN

DATE: 07 NOV 2022

CONSTRUCTION DRAWINGS

SCM PLAN

Job Code: SCBSZ

Dwg No. **SITE 301**

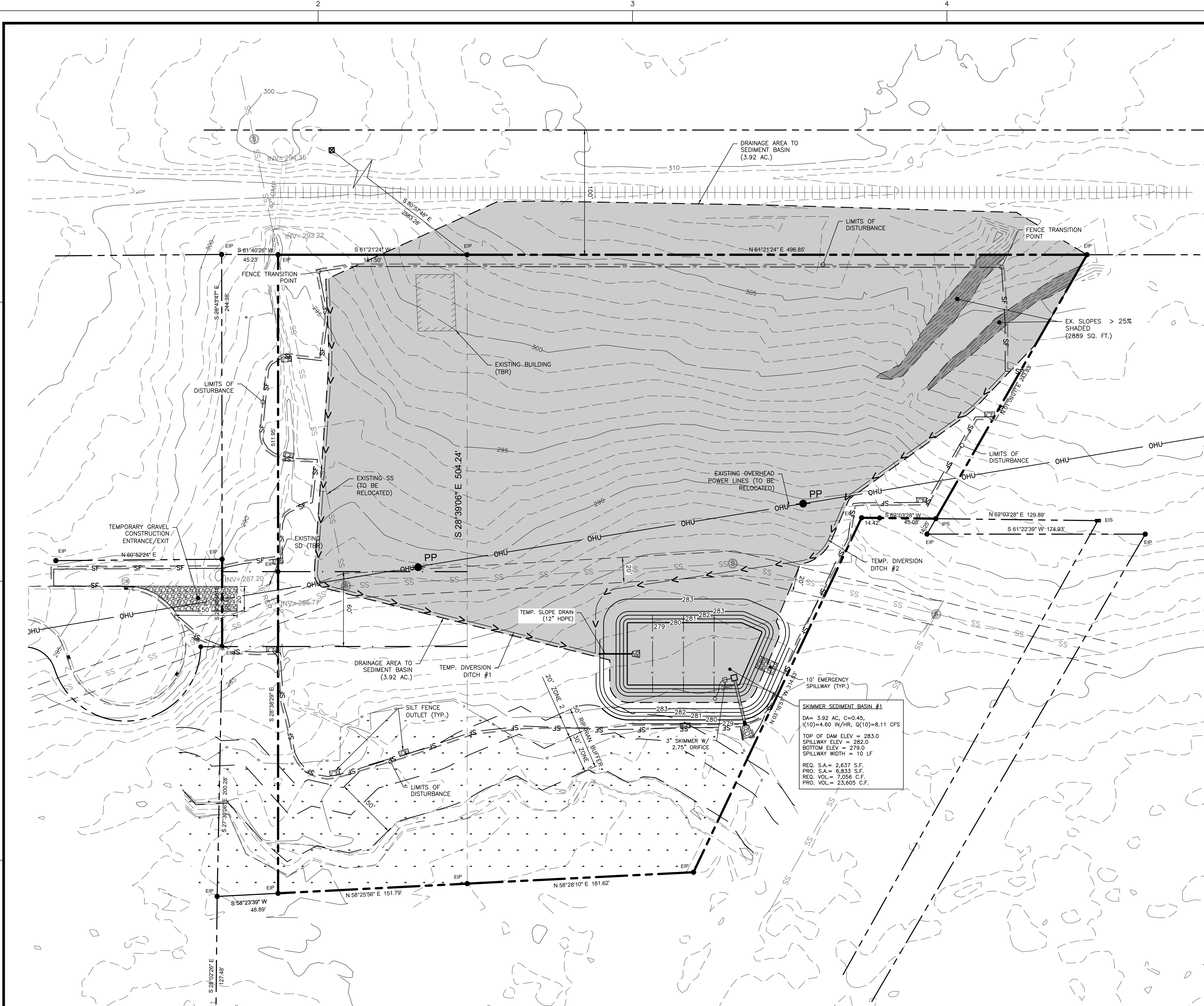

EROSION CONTROL NOTES

- ALL CONSTRUCTION SHALL COMPLY WITH TOWN OF ZEBULON STANDARDS AND SPECIFICATIONS.
- EXISTING CONDITION INFORMATION SHOWN IS TAKEN FROM A SURVEY BY ANGLE RIGHT LAND SURVEYING, PLLC DATED JUNE 1, 2022.
- THE CONTRACTOR SHALL BE RESPONSIBLE FOR CONTACTING, COORDINATING, AND PAYMENT FOR ALL NECESSARY LOCATING SERVICES INCLUDING INDEPENDENT LOCATING SERVICES. THE CONTRACTOR SHALL HAVE ALL EXISTING UTILITIES LOCATED AT LEAST 48 HOURS PRIOR TO BEGINNING DEMOLITION, EXCAVATION, OR ANY OTHER FORM OF CONSTRUCTION. THE CONTRACTOR SHALL IMMEDIATELY NOTIFY THE OWNER'S REPRESENTATIVE OR ANY DISCREPANCIES OR CONFLICTS.
- EXISTING IMPROVEMENTS DAMAGED OR DESTROYED BY THE CONTRACTOR DURING CONSTRUCTION SHALL BE RESTORED OR REPLACED TO ORIGINAL CONDITION AND TO THE SATISFACTION OF THE OWNER'S REPRESENTATIVE AT THE CONTRACTOR'S EXPENSE.
- THE CONTRACTOR SHALL BE RESPONSIBLE FOR ENSURING ALL PERMITS, INSPECTIONS, CERTIFICATIONS, AND OTHER REQUIREMENTS WHICH MUST BE MET UNDER THIS CONTRACT ARE OBTAINED.
- IF DEPARTURES FROM THE PROJECT DRAWINGS OR SPECIFICATIONS ARE DEEMED NECESSARY BY THE CONTRACTOR, DETAILS OF SUCH DEPARTURES AND REASONS THEREFOR SHALL BE SUBMITTED TO THE OWNER'S REPRESENTATIVE FOR REVIEW PRIOR TO CONSTRUCTION. NO DEPARTURES FROM THE CONTRACT DOCUMENTS SHALL BE MADE WITHOUT THE EXPRESS WRITTEN PERMISSION OF THE OWNER'S REPRESENTATIVE.
- THE ENGINEER DISCLAIMS ANY ROLE IN THE CONSTRUCTION MEANS AND/OR METHODS ASSOCIATED WITH THE PROJECT AS SET FORTH IN THESE PLANS.
- THE STREETS IN FRONT OF THE PROJECT WILL BE KEPT CLEAN AT ALL TIMES OR A WASH STATION WILL BE REQUIRED.
- THE TREE PROTECTION FENCE SHALL BE MAINTAINED ON THE SITE UNTIL ALL SITE WORK IS COMPLETED AND THE FINAL SITE INSPECTION IS SCHEDULED PRIOR TO THE ISSUANCE OF A CERTIFICATE OF OCCUPANCY (CO). THE FENCING SHALL BE REMOVED IMMEDIATELY PRIOR TO THE FINAL SITE INSPECTION FOR THE SITE.
- TREE PROTECTION FENCING SHALL NOT BE MOVED AND THERE SHALL BE NO ENCROACHMENT INTO SUCH PROTECTED AREA(S) WITHOUT WRITTEN AUTHORIZATION OF THE TOWN'S ZONING COMPLIANCE STAFF. ANY ACTIVITY (LANDSCAPING, FENCING, OR UTILITY INSTALLATION) SHOWN ON THE APPROVED PLANS IN A TREE PROTECTION AREA, SHALL ALSO NOT OCCUR WITHOUT WRITTEN AUTHORIZATION FROM THE TOWN'S ZONING COMPLIANCE STAFF. ANY UNAUTHORIZED ENCROACHMENT OR DISTURBANCE WITHIN THE BOUNDARIES OF A TREE PROTECTION AREA SHALL AUTOMATICALLY RESULT IN FINES AND THE REPLACEMENT OF ANY DAMAGED VEGETATION IN ACCORDANCE WITH THE LAND DEVELOPMENT ORDINANCE.

CONSTRUCTION SEQUENCE (INITIAL PHASE):

- OBTAIN A LAND DISTURBING PERMIT.
- PRIOR TO BEGINNING CONSTRUCTION, CALL THE STORMWATER INSPECTOR TO SCHEDULE AN ON-SITE PRECONSTRUCTION MEETING.
- CLEAR ONLY AS NECESSARY TO INSTALL ALL TEMPORARY EROSION AND SEDIMENT CONTROL MEASURES AS SHOWN ON THE INITIAL EROSION CONTROL PLAN (PAGE 1):
 - INSTALL CONSTRUCTION ENTRANCE.
 - INSTALL SILT FENCING AND SILT FENCE OUTLETS.
 - INSTALL DIVERSION DITCHES.
 - INSTALL SEDIMENT SKIMMER BASIN.
- MAINTAIN EROSION CONTROL MEASURES UNTIL PERMANENT GROUND COVER IS ESTABLISHED.
- STABILIZATION IS REQUIRED WITHIN 14 CALENDAR DAYS OF COMPLETION OF ANY PHASE OF GRADING OR INACTIVITY ON PROJECT SITE.
- SCHEDULE A SITE INSPECTION THROUGH WAKE COUNTY.
- UPON APPROVAL OF THE STORMWATER SITE INSPECTION, DEMOLISH EXISTING STRUCTURES AS DETAILED ON EXISTING CONDITION AND DEMOLITION PLAN.
- PROCEED TO PHASE 2 OF THE EROSION CONTROL SEQUENCE. SEE SITE 303.

NPDES GROUND STABILIZATION

SITE AREA DESCRIPTION	STABILIZATION TIME FRAME	STABILIZATION TIME FRAME EXCEPTIONS
PERIMETER DIKES, SWALES, DITCHES AND SLOPES	7 DAYS	NONE
HIGH QUALITY WATER (HOW) ZONES	7 DAYS	NONE
SLOPES STEEPER THAN 3:1	7 DAYS	IF SLOPES ARE 10' OR LESS IN LENGTH AND ARE NOT STEEPER THAN 2:1, 14 DAYS ARE ALLOWED
SLOPES 3:1 OR FLATTER	14 DAYS	7-DAYS FOR SLOPES GREATER THAN 50 FEET IN LENGTH
ALL OTHER AREAS WITH SLOPES FLATTER THAN 4:1	14 DAYS	NONE (EXCEPT FOR PERIMETERS AND HOW ZONES)

SKIMMER SEDIMENT BASIN #1
 DA = 3.92 AC, C=0.45,
 (10)=4.60 IN/HR, Q(10)=8.11 CFS
 TOP OF DAM ELEV = 283.0
 SPILLWAY ELEV = 282.0
 BOTTOM ELEV = 279.0
 SPILLWAY WIDTH = 10 LF
 REQ. S.A. = 2,637 S.F.
 PRO. S.A. = 6,833 S.F.
 REQ. VOL. = 7,056 C.F.
 PRO. VOL. = 23,605 C.F.

EROSION CONTROL LEGEND

	EXISTING MINOR TOPO		TEMPORARY CHECK DAM
	EXISTING MAJOR TOPO		TEMPORARY CONSTRUCTION ENTRANCE
	EXISTING GAS LINE		SILT FENCE OUTLET
	EXISTING STORM DRAINAGE		INLET PROTECTION
	EXISTING RIPARIAN BUFFER		
	PROPOSED SILT FENCE		
	PROPOSED LIMITS OF DISTURBANCE		
	TREE PROTECTION FENCE		

DRAINAGE SWALE CHART

Swale Number	Swale Bottom Width (ft)	Side Slope	Depth of Swale (ft)	Channel Slope (ft/ft)	Depth of Flow Q10 (in)	Velocity Q10 (fps)	Temporary Liner	Permanent Liner
1	1	2	1	0.0318	8.3	2.6	S75	N/A
2	1	2	1	0.0479	7.2	6.4	SC150	N/A

DISTURBED AREA
 194,349 SF / 4.46 AC

NORTH

INITIAL EROSION CONTROL PLAN

SCALE: 1" = 40' (DRAWING SCALED FOR 24x36 INCH PLOTS)



NC ENGINEERING LICENSE NO. P-8803



PRELIMINARY FOR REVIEW ONLY

THE SITE GROUP
 CIVIL ENGINEERS • LANDSCAPE ARCHITECTS
 THE SITE GROUP, PLLC
 1111 W. WAKE RD.
 RALEIGH, NC 27605-1136 USA
 Office: 919.835.4787
 Fax: 919.835.2255
 E-Mail: SRN@thesitegroup.net

CONSTRUCTION DRAWINGS FOR:
BARBEE ST. SUBDIVISION
 0 E. BARBEE STREET
 ZEBULON, NORTH CAROLINA

Drawn By: **WRR**
 Checked By: **SRN**

DATE:
 07 NOV 2022

CONSTRUCTION DRAWINGS

INITIAL EROSION CONTROL PLAN

Job Code: **SCBSZ**

Dwg No.
SITE 302

EROSION CONTROL NOTES

- ALL CONSTRUCTION SHALL COMPLY WITH TOWN OF ZEBULON STANDARDS AND SPECIFICATIONS.
- EXISTING CONDITION INFORMATION SHOWN IS TAKEN FROM A SURVEY BY ANGLE RIGHT LAND SURVEYING, PLLC DATED JUNE 1, 2022.
- THE CONTRACTOR SHALL BE RESPONSIBLE FOR CONTACTING, COORDINATING, AND PAYMENT FOR ALL NECESSARY LOCATING SERVICES INCLUDING INDEPENDENT LOCATING SERVICES. THE CONTRACTOR SHALL HAVE ALL EXISTING UTILITIES LOCATED AT LEAST 48 HOURS PRIOR TO BEGINNING DEMOLITION, EXCAVATION, OR ANY OTHER FORM OF CONSTRUCTION. THE CONTRACTOR SHALL IMMEDIATELY NOTIFY THE OWNER'S REPRESENTATIVE OR ANY DISCREPANCIES OR CONFLICTS.
- EXISTING IMPROVEMENTS DAMAGED OR DESTROYED BY THE CONTRACTOR DURING CONSTRUCTION SHALL BE RESTORED OR REPLACED TO ORIGINAL CONDITION AND TO THE SATISFACTION OF THE OWNER'S REPRESENTATIVE AT THE CONTRACTOR'S EXPENSE.
- THE CONTRACTOR SHALL BE RESPONSIBLE FOR ENSURING ALL PERMITS, INSPECTIONS, CERTIFICATIONS, AND OTHER REQUIREMENTS WHICH MUST BE MET UNDER THIS CONTRACT ARE OBTAINED.
- IF DEPARTURES FROM THE PROJECT DRAWINGS OR SPECIFICATIONS ARE DEEMED NECESSARY BY THE CONTRACTOR, DETAILS OF SUCH DEPARTURES AND REASONS THEREFORE SHALL BE SUBMITTED TO THE OWNER'S REPRESENTATIVE FOR REVIEW PRIOR TO CONSTRUCTION. NO DEPARTURES FROM THE CONTRACT DOCUMENTS SHALL BE MADE WITHOUT THE EXPRESS WRITTEN PERMISSION OF THE OWNER'S REPRESENTATIVE.
- THE ENGINEER DISCLAIMS ANY ROLE IN THE CONSTRUCTION MEANS AND/OR METHODS ASSOCIATED WITH THE PROJECT AS SET FORTH IN THESE PLANS.
- THE STREETS IN FRONT OF THE PROJECT WILL BE KEPT CLEAN AT ALL TIMES OR A WASH STATION WILL BE REQUIRED.
- THE TREE PROTECTION FENCE SHALL BE MAINTAINED ON THE SITE UNTIL ALL SITE WORK IS COMPLETED AND THE FINAL SITE INSPECTION IS SCHEDULED PRIOR TO THE ISSUANCE OF A CERTIFICATE OF OCCUPANCY (CO). THE FENCING SHALL BE REMOVED IMMEDIATELY PRIOR TO THE FINAL SITE INSPECTION FOR THE SITE.
- TREE PROTECTION FENCING SHALL NOT BE MOVED AND THERE SHALL BE NO ENCROACHMENT INTO SUCH PROTECTED AREA(S) WITHOUT WRITTEN AUTHORIZATION OF THE TOWN'S ZONING COMPLIANCE STAFF. ANY ACTIVITY (LANDSCAPING, FENCING, OR UTILITY INSTALLATION) SHOWN ON THE APPROVED PLANS IN A TREE PROTECTION AREA, SHALL ALSO NOT OCCUR WITHOUT WRITTEN AUTHORIZATION FROM THE TOWN'S ZONING COMPLIANCE STAFF. ANY UNAUTHORIZED ENCROACHMENT OR DISTURBANCE WITHIN THE BOUNDARIES OF A TREE PROTECTION AREA SHALL AUTOMATICALLY RESULT IN FINES AND THE REPLACEMENT OF ANY DAMAGED VEGETATION IN ACCORDANCE WITH THE LAND DEVELOPMENT ORDINANCE.

CONSTRUCTION SEQUENCE (FINAL PHASE):

- CONTINUED FROM SITE 302
- COMMENCE PERMITTED LAND DISTURBING ACTIVITY.
 - PROCEED WITH CLEARING, GRUBBING AND GRADING. ADJUST TEMPORARY DIVERSIONS AS REQUIRED.
 - MAINTAIN ALL EROSION AND SEDIMENT CONTROL MEASURES IN GOOD WORKING ORDER. SILT FENCE, INLET PROTECTION AND OTHER SIMILAR MEASURES MUST BE CLEANED OUT BEFORE THEY ARE HALF FULL. CLOGGED STONE FILTERS MUST BE REFRESHED/REPLACED. SILT FENCE CAN NOT HAVE HOLES OR TEARS.
 - INSTALL ALL UTILITIES, STORMWATER PIPES, INLETS, ROAD BEDS, CURB AND GUTTER AND RETAINING WALLS.
 - STABILIZATION IS REQUIRED WITHIN 14 CALENDAR DAYS OF COMPLETION OF ANY PHASE OF GRADING OR INACTIVITY ON PROJECT SITE.
 - SUBMIT DOCUMENTATION REQUIRED UNDER THE SITE NPDES STORMWATER PERMIT FOR CONSTRUCTION ACTIVITY (CNG010000) TO STORMWATER INSPECTIONS THROUGHOUT THE PROJECT.
 - SCHEDULE A SITE INSPECTION THROUGH WAKE COUNTY.
 - INSTALL RESIDENTIAL CONSTRUCTION ENTRANCES AT EACH BUILDING.
 - INSTALL SILT FENCE WITH SILT FENCE OUTLETS AROUND EACH BUILDING.
 - PROTECT ALL INLETS AS INSTALLED.
 - MAINTAIN ALL EROSION AND SEDIMENT CONTROL MEASURES IN GOOD WORKING ORDER. SILT FENCE, INLET PROTECTION AND OTHER SIMILAR MEASURES MUST BE CLEANED OUT BEFORE THEY ARE HALF FULL. CLOGGED STONE FILTERS MUST BE REFRESHED/REPLACED. SILT FENCE CAN NOT HAVE HOLES OR TEARS.
 - WHEN AREA TRIBUTARY TO SEDIMENT BASIN #1 HAS BEEN STABILIZED, CONVERT SEDIMENT BASIN #1 TO FINAL CONFIGURATION.
 - DEWATER BASIN AND REMOVE ACCUMULATED SEDIMENT. UTILIZE SILT BAG FOR DEWATERING.
 - INSTALL INTERIOR RETAINING WALL.
 - REMOVE TEMPORARY SLOPE DRAIN AND INSTALL FES #1, FES#21 & RIP-RAP DISSIPATER PAD
 - SET GRADES TO FINAL ELEVATIONS.
 - REMOVE SKIMMER AND SET OUTLET STRUCTURE WEIRS/ORIFICES TO FINAL CONFIGURATION.
 - CALL SAM NYE AT 919-835-4787 FOR SITE INSPECTION A MINIMUM TWO WEEKS PRIOR TO REQUESTING TOWN FINAL INSPECTION.
 - ONCE APPROVED, SURVEY EXISTING SCM TOPO AND STRUCTURE ELEVATIONS. AS-BUILTS MUST BE COMPLETED AND SUBMITTED ONE WEEK PRIOR TO FINAL INSPECTION.
 - STABILIZATION IS REQUIRED WITHIN 14 CALENDAR DAYS OF COMPLETION OF ANY PHASE OF GRADING OR INACTIVITY ON PROJECT SITE.
 - SCHEDULE THE FINAL SITE INSPECTION THROUGH WAKE COUNTY.
 - SUBMIT DOCUMENTATION REQUIRED UNDER THE SITE NPDES STORMWATER PERMIT FOR CONSTRUCTION ACTIVITY (CNG010000) TO STORMWATER INSPECTIONS THROUGHOUT THE PROJECT.

NPDES GROUND STABILIZATION

SITE AREA DESCRIPTION	STABILIZATION TIME FRAME	STABILIZATION TIME FRAME EXCEPTIONS
PERIMETER DIKES, SWALES, DITCHES AND SLOPES	7 DAYS	NONE
HIGH QUALITY WATER (HQW) ZONES	7 DAYS	NONE
SLOPES STEEPER THAN 3:1	7 DAYS	IF SLOPES ARE 10' OR LESS IN LENGTH AND ARE NOT STEEPER THAN 2:1, 14 DAYS ARE ALLOWED
SLOPES 3:1 OR FLATTER	14 DAYS	7-DAYS FOR SLOPES GREATER THAN 50 FEET IN LENGTH
ALL OTHER AREAS WITH SLOPES FLATTER THAN 4:1	14 DAYS	NONE (EXCEPT FOR PERIMETERS AND HQW ZONES)

EROSION CONTROL PLAN

SCALE: 1" = 40' (DRAWING SCALED FOR 24x36 INCH PLOTS)

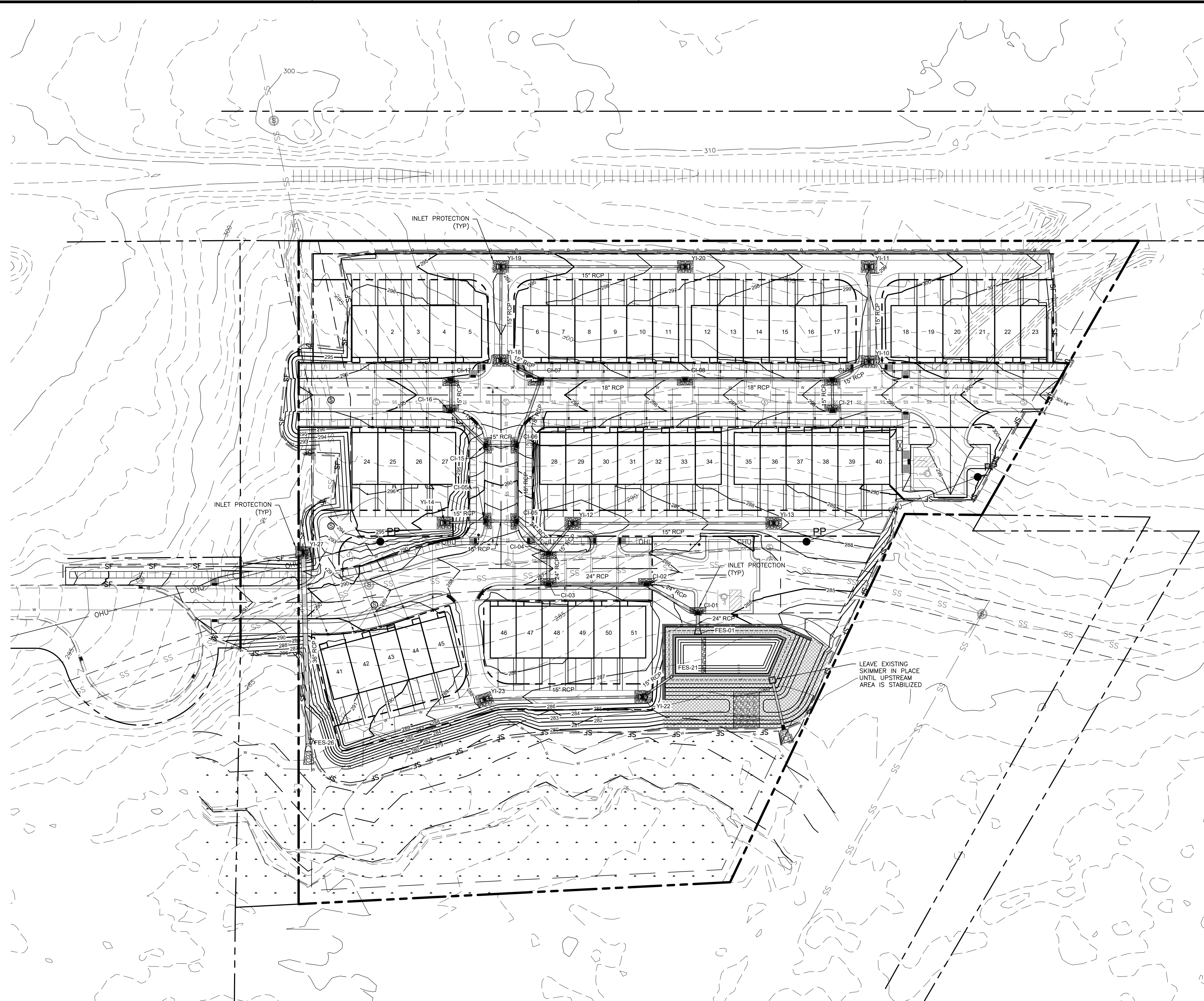
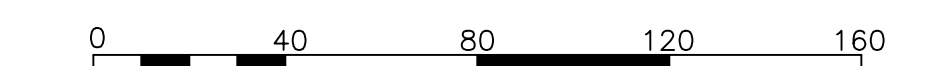

EROSION CONTROL LEGEND

	EXISTING MINOR TOPO		TEMPORARY CHECK DAM
	EXISTING MAJOR TOPO		TEMPORARY CONSTRUCTION ENTRANCE
	EXISTING GAS LINE		SILT FENCE OUTLET
	EXISTING STORM DRAINAGE		INLET PROTECTION
	EXISTING RIPARIAN BUFFER		
	PROPOSED SILT FENCE		
	PROPOSED LIMITS OF DISTURBANCE		
	TREE PROTECTION FENCE		

DRAINAGE SWALE CHART

Swale Number	Swale Bottom Width (ft)	Side Slope	Depth of Swale (ft)	Channel Slope (ft/ft)	Depth of Flow Q10 (in)	Velocity Q10 (fps)	Temporary Liner	Permanent Liner
1	A	B	C	0.0318	8.3	2.6	S75	N/A
2	1	2	1	0.0479	7.2	6.4	SC150	N/A

DISTURBED AREA
194,349 SF / 4.46 AC



NO ENGINEERING LICENSE NO. P-0803



PRELIMINARY FOR REVIEW ONLY

THE SITE GROUP
CIVIL ENGINEERS • LANDSCAPE ARCHITECTS
THE SITE GROUP, PLLC
1000 N. W. 27th St., Suite 200
Raleigh, NC 27605-1136 USA
Phone: 919.835.4787
Fax: 919.839.2255
E-Mail: SRN@thesitegroup.net

CONSTRUCTION DRAWINGS FOR:
BARBEE ST. SUBDIVISION
0 E. BARBEE STREET
ZEBULON, NORTH CAROLINA

Drawn By: **WRR**
Checked By: **SRN**

DATE:
07 NOV 2022

CONSTRUCTION DRAWINGS

EROSION CONTROL PLAN

Job Code: **SCBSZ**

Dwg No.
SITE 303

GROUND STABILIZATION AND MATERIALS HANDLING PRACTICES FOR COMPLIANCE WITH THE NCG01 CONSTRUCTION GENERAL PERMIT
 Implementing the details and specifications on this plan sheet will result in the construction activity being considered compliant with the Ground Stabilization and Materials Handling sections of the NCG01 Construction General Permit (Sections E and F, respectively). The permittee shall comply with the Erosion and Sediment Control plan approved by the delegated authority having jurisdiction. All details and specifications shown on this sheet may not apply depending on site conditions and the delegated authority having jurisdiction.

SECTION E: GROUND STABILIZATION

Site Area Description	Stabilize within this many calendar days after ceasing land disturbance	Timeframe variations
(a) Perimeter dikes, swales, ditches, and perimeter slopes	7	None
(b) High Quality Water (HQW) Zones	7	None
(c) Slopes steeper than 3:1	7	If slopes are 10' or less in length and are not steeper than 2:1, 14 days are allowed.
(d) Slopes 3:1 to 4:1	14	- 7 days for slopes greater than 50' in length and with slopes steeper than 4:1 - 7 days for perimeter dikes, swales, ditches, perimeter slopes and HQW Zones - 10 days for Falls Lake Watershed
(e) Areas with slopes flatter than 4:1	14	- 7 days for perimeter dikes, swales, ditches, perimeter slopes and HQW Zones - 10 days for Falls Lake Watershed unless there is zero slope.

Note: After the permanent cessation of construction activities, any areas with temporary ground stabilization shall be converted to permanent ground stabilization as soon as practicable but in no case longer than 90 calendar days after the last land disturbing activity. Temporary ground stabilization shall be maintained in a manner to render the surface stable against accelerated erosion until permanent ground stabilization is achieved.

GROUND STABILIZATION SPECIFICATION
 Stabilize the ground sufficiently so that rain will not dislodge the soil. Use one of the techniques in the table below:

Temporary Stabilization	Permanent Stabilization
<ul style="list-style-type: none"> Temporary grass seed covered with straw or other mulches and tackifiers Hydroseeding Roll-on erosion control products with or without temporary grass seed Appropriately applied straw or other mulch Plastic sheeting 	<ul style="list-style-type: none"> Permanent grass seed covered with straw or other mulches and tackifiers Essential fabrics such as geotextile soil reinforcement matting Hydroseeding Driveways or other permanent plantings covered with mulch Uniform and evenly distributed ground cover sufficient to restrain erosion Structural methods such as concrete, asphalt or retaining walls Roll-on erosion control products with grass seed

- POLYACRYLAMIDES (PAMS) AND FLOCCULANTS**
- Select flocculants that are appropriate for the soils being exposed during construction, selecting from the NC DWR List of Approved PAMS/Flocculants.
 - Apply flocculants at or before the inlets to Erosion and Sediment Control Measures.
 - Apply flocculants at the concentrations specified in the NC DWR List of Approved PAMS/Flocculants and in accordance with the manufacturer's instructions.
 - Provide ponding area for containment of treated Stormwater before discharging off-site.
 - Store flocculants in leak-proof containers that are kept under storm-resistant cover or surrounded by secondary containment structures.

- EQUIPMENT AND VEHICLE MAINTENANCE**
- Maintain vehicles and equipment to prevent discharge of fluids.
 - Provide drip pans under any stored equipment.
 - Identify leaks and repair as soon as feasible, or remove leaking equipment from the project.
 - Collect all spent fluids, store in separate containers and properly dispose as hazardous waste (recycle when possible).
 - Remove leaking vehicles and construction equipment from service until the problem has been corrected.
 - Bring used fuels, lubricants, coolants, hydraulic fluids and other petroleum products to a recycling or disposal center that handles these materials.

- LITTER, BUILDING MATERIAL AND LAND CLEARING WASTE**
- Never bury or burn waste. Place litter and debris in approved waste containers.
 - Provide a sufficient number and size of waste containers (e.g. dumpster, trash receptacle) on site to contain construction and domestic wastes.
 - Locate waste containers at least 50 feet away from storm drain inlets and surface waters unless no other alternatives are reasonably available.
 - Locate waste containers on areas that do not receive substantial amounts of runoff from upland areas and does not drain directly to a storm drain, stream or wetland.
 - Cover waste containers at the end of each workday and before storm events or provide secondary containment. Repair or replace damaged waste containers.
 - Anchor all lightweight items in waste containers during times of high winds.
 - Empty waste containers as needed to prevent overflow. Clean up immediately if containers overflow.
 - Dispose waste off-site at an approved disposal facility.
 - On business days, clean up and dispose of waste in designated waste containers.

- PAINT AND OTHER LIQUID WASTE**
- Do not dump paint and other liquid waste into storm drains, streams or wetlands.
 - Locate paint washouts at least 50 feet away from storm drain inlets and surface waters unless no other alternatives are reasonably available.
 - Contain liquid wastes in a controlled area.
 - Containment must be labeled, sized and placed appropriately for the needs of site.
 - Prevent the discharge of soaps, solvents, detergents and other liquid wastes from construction sites.

- PORTABLE TOILETS**
- Install portable toilets on level ground, at least 50 feet away from storm drains, streams or wetlands unless there is no alternative reasonably available. If 50 foot offset is not attainable, provide relocation of portable toilet behind silt fence or place on a gravel pad and surround with sand bags.
 - Provide staking or anchoring of portable toilets during periods of high winds or in high foot traffic areas.
 - Monitor portable toilets for leaking and properly dispose of any leaked material. Utilize a licensed sanitary waste hauler to remove leaking portable toilets and replace with properly operating unit.

- EARTHEN STOCKPILE MANAGEMENT**
- Show stockpile locations on plans. Locate earthen-material stockpile areas at least 50 feet away from storm drain inlets, sediment basins, perimeter sediment controls and surface waters unless it can be shown no other alternatives are reasonably available.
 - Protect stockpile with silt fence installed along toe of slope with a minimum offset of five feet from the toe of stockpile.
 - Provide stable stone access point when feasible.
 - Stabilize stockpile within the timeframes provided on this sheet and in accordance with the approved plan and any additional requirements. Soil stabilization is defined as vegetative, physical or chemical coverage techniques that will restrain accelerated erosion on disturbed soils for temporary or permanent control needs.

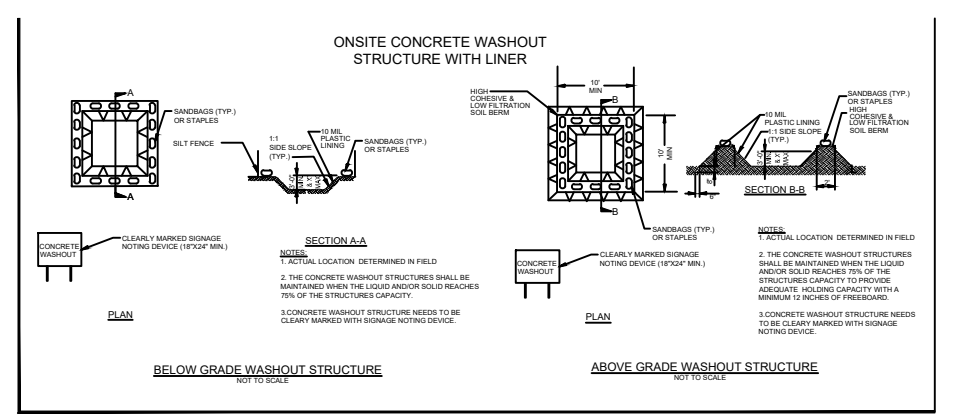

- CONCRETE WASHOUTS**
- Do not discharge concrete or cement slurry from the site.
 - Dispose of, or recycle settled, hardened concrete residue in accordance with local and state solid waste regulations and at an approved facility.
 - Manage washout from mortar mixers in accordance with the above item and in addition place the mixer and associated material on impervious barrier and within lot perimeter silt fence.
 - Install temporary concrete washouts per local requirements, where applicable. If an alternate method or product is to be used, contact your approval authority for review and approval. If local standard details are not available, use one of the two types of temporary concrete washouts provided on this detail.
 - Do not use concrete washouts for dewatering or storing defective curb or sidewalk sections. Stormwater accumulated within the washout may not be pumped into or discharged to the storm drain system or receiving surface waters. Liquid waste must be pumped out and removed from project.
 - Locate washouts at least 50 feet from storm drain inlets and surface waters unless it can be shown that no other alternatives are reasonably available. At a minimum, install protection of storm drain inlet(s) closest to the washout which could receive spills or overflow.
 - Locate washouts in an easily accessible area, on level ground and install a stone entrance pad in front of the washout. Additional controls may be required by the approving authority.
 - Install at least one sign directing concrete trucks to the washout within the project limits. Post signage on the washout itself to identify this location.
 - Remove leavings from the washout when at approximately 75% capacity to limit overflow events. Replace the tarp, sand bags or other temporary structural components when no longer functional. When utilizing alternative or proprietary products, follow manufacturer's instructions.
 - At the completion of the concrete work, remove remaining leavings and dispose of in an approved disposal facility. Fill pit, if applicable, and stabilize any disturbance caused by removal of washout.

- HERBICIDES, PESTICIDES AND RODENTICIDES**
- Store and apply herbicides, pesticides and rodenticides in accordance with label restrictions.
 - Store herbicides, pesticides and rodenticides in their original containers with the label, which lists directions for use, ingredients and first aid steps in case of accidental poisoning.
 - Do not store herbicides, pesticides and rodenticides in areas where flooding is possible or where they may spill or leak into wells, stormwater drains, ground water or surface water. If a spill occurs, clean area immediately.
 - Do not stockpile these materials onsite.

- HAZARDOUS AND TOXIC WASTE**
- Create designated hazardous waste collection areas on-site.
 - Place hazardous waste containers under cover or in secondary containment.
 - Do not store hazardous chemicals, drums or bagged materials directly on the ground.

NPDES GROUND STABILIZATION SCHEDULE

SITE AREA DESCRIPTION	STABILIZATION TIME FRAME	STABILIZATION TIME FRAME EXCEPTIONS	AREAS ON THIS SITE
PERIMETER DIKES, SWALES, DITCHES AND SLOPES STEEPER THAN 3:1	7 DAYS	NONE	TEMPORARY DIVERSION DITCHES
SLOPES STEEPER THAN 3:1	7 DAYS	IF SLOPES ARE 10' OR LESS IN LENGTH AND ARE NOT STEEPER THAN 2:1, 14 DAYS ARE ALLOWED	NONE
SLOPES 3:1 OR FLATTER	14 DAYS	7-DAYS FOR SLOPES GREATER THAN 50 FEET IN LENGTH	REMAINDER OF PROJECT AREA
ALL OTHER AREAS WITH SLOPES FLATTER THAN 4:1	14 DAYS	NONE (EXCEPT FOR PERIMETERS AND HQW ZONES)	INCLUDED W/ 3:1 OR FLATTER SLOPES

- NPDES PLAN NOTES**
- THIS PAGE IS SUBMITTED TO COMPLY WITH NPDES GENERAL STORMWATER PERMIT NCG010000.
 - THIS PAGE CAN BE APPROVED BY THE CITY PURSUANT TO NPDES GENERAL STORMWATER PERMIT NCG010000 ONLY.
 - THIS PAGE OF THE APPROVED PLANS IS ENFORCEABLE EXCLUSIVELY PURSUANT TO NPDES GENERAL STORMWATER PERMIT NCG010000.

NCG01 GROUND STABILIZATION AND MATERIALS HANDLING EFFECTIVE: 04/01/19

PART III SELF-INSPECTION, RECORDKEEPING AND REPORTING

SECTION A: SELF-INSPECTION
 Self-inspections are required during normal business hours in accordance with the table below. When adverse weather or site conditions would cause the safety of the inspection personnel to be in jeopardy, the inspection may be delayed until the next business day on which it is safe to perform the inspection. In addition, when a storm event of equal to or greater than 1.0 inch outside of normal business hours, the self-inspection shall be performed upon the commencement of the next business day. Any time when inspections were delayed shall be noted in the Inspection Record.

Inspect	Frequency (during normal business hours)	Inspection records must include:
(1) Rain gauge maintained in good working order	Daily	Daily rainfall amounts. If no daily rain gauge observations are made during weekend or holiday periods, and no individual day rainfall information is available, record the cumulative rain measurement for those un-attended days (and this will determine if a site inspection is needed). Days on which no rainfall occurred shall be denoted as "zero". The permittee may use another rain-measuring device approved by the Division.
(2) E&S Measures	At least once per 7 calendar days and within 24 hours of a rain event > 1.0 inch in 24 hours	1. Identification of the measures inspected. 2. Date and time of the inspection. 3. Name of the person performing the inspection. 4. Indication of whether the measures were operating properly. 5. Description of maintenance needs for the measure. 6. Description, evidence, and date of corrective actions taken.
(3) Stormwater discharge outfall(S)OOS	At least once per 7 calendar days and within 24 hours of a rain event > 1.0 inch in 24 hours	1. Identification of the discharge outfall inspected. 2. Date and time of the inspection. 3. Name of the person performing the inspection. 4. Evidence of isolation of observed problems such as soil slough, flooding or suspended solids or discoloration. 5. Indication of whether sediment leaving the site. 6. Description, evidence, and date of corrective actions taken.
(4) Perimeter of site	At least once per 7 calendar days and within 24 hours of a rain event > 1.0 inch in 24 hours	If visible sedimentation is found outside site limits, then a record of the following shall be made: 1. Actions taken to clean up or stabilize the sediment that has left the site limits. 2. Description, evidence, and date of corrective actions taken. 3. An explanation as to the actions taken to control future outfalls.
(5) Streams or wetlands on-site or off-site (where accessible)	At least once per 7 calendar days and within 24 hours of a rain event > 1.0 inch in 24 hours	If the stream or wetland has increased visible sedimentation or a stream has had an increased turbidity from the construction activity, then a record of the following shall be made: 1. Description, evidence and date of corrective actions taken, and 2. Record of the required report to the appropriate Division Regional Office per Part III, Section C, Item 2)(c) of this permit.
(6) Ground stabilization measures	After each phase of grading	1. The date of ground stabilization or other E&S measures, clearing and grubbing, installation of storm drainage facilities, cessation of all land disturbing activity, construction or redevelopment permit, ground cover). 2. Documentation that the required ground stabilization measures have been provided within the required timeframe or an assurance that they will be provided as soon as possible.

NOTE: The rain inspection resets the required 7 calendar day inspection requirement.

- PART III SELF-INSPECTION, RECORDKEEPING AND REPORTING**
- SECTION B: RECORDKEEPING**
- 1. E&S Plan Documentation**
 The approved E&S plan as well as any approved deviation shall be kept on the site. The approved E&S plan must be kept up-to-date throughout the coverage under this permit. The following items pertaining to the E&S plan shall be kept on site and available for inspection at all times during normal business hours.
- | Item to Document | Documentation Requirements |
|---|--|
| (a) Each E&S measure has been installed and does not significantly erode from the locations, dimensions and relative elevations shown on the approved E&S plan. | Initial and date each E&S measure on a copy of the approved E&S plan or complete, date and sign an inspection report that lists each E&S measure shown on the approved E&S plan. This document shall be required upon the initial installation of the E&S measures or if the E&S measures are modified after initial installation. |
| (b) A phase of grading has been completed. | Initial and date a copy of the approved E&S plan or complete, date and sign an inspection report to indicate completion of the construction phase. |
| (c) Ground cover is located and installed in accordance with the approved E&S plan. | Initial and date a copy of the approved E&S plan or complete, date and sign an inspection report to indicate compliance with approved ground cover specifications. |
| (d) The maintenance and repair requirements for E&S measures have been performed. | Complete, date and sign an inspection report. |
| (e) Corrective actions have been taken to E&S measures. | Initial and date a copy of the approved E&S plan or complete, date and sign an inspection report to indicate the completion of the corrective action. |
- 2. Additional Documentation to be Kept on Site**
 In addition to the E&S plan documents above, the following items shall be kept on the site and available for inspectors at all times during normal business hours, unless the Division provides a site-specific exemption based on unique site conditions that make this requirement not practical:
- This General Permit as well as the Certificate of Coverage, after it is received.
 - Records of inspections made during the previous twelve months. The permittee shall record the required observations on the Inspection Record Form provided by the Division or a similar inspection form that includes all the required elements. Use of electronically available records in lieu of the required paper copies will be allowed if shown to provide equal access and utility as the hard-copy records.
- 3. Documentation to be Retained for Three Years**
 All data used to complete the e-NDI and all inspection records shall be maintained for a period of three years after project completion and made available upon request. (40 CFR 122.41)

- PART III SELF-INSPECTION, RECORDKEEPING AND REPORTING**
- SECTION C: REPORTING**
- 1. Occurrences that Must be Reported**
 Permittees shall report the following occurrences:
- Visible sediment deposition in a stream or wetland.
 - Oil spills if:
 - They are 25 gallons or more,
 - They are less than 25 gallons but cannot be cleaned up within 24 hours,
 - They cause sheen on surface waters (regardless of volume), or
 - They are within 100 feet of surface waters (regardless of volume).
 - Releases of hazardous substances in excess of reportable quantities under Section 311 of the Clean Water Act (Ref. 40 CFR 113.3 and 40 CFR 117.3) or Section 102 of CERCLA (Ref. 40 CFR 302.4) or G.S. 143-215.85.
 - Anticipated bypasses and unanticipated bypasses.
 - Noncompliance with the conditions of this permit that may endanger health or the environment.
- 2. Reporting Timeframes and Other Requirements**
 After a permittee becomes aware of an occurrence that must be reported, he shall contact the appropriate Division regional office within the timeframes and in accordance with the other requirements listed below. Occurrences outside normal business hours may also be reported to the Department's Environmental Emergency Center personnel at (800) 858-0368.
- | Occurrences | Reporting Timeframes (After Discovery) and Other Requirements |
|---|---|
| (a) Visible sediment deposition in a stream or wetland | <ul style="list-style-type: none"> Within 24 hours, an oral or electronic notification. Within 7 calendar days, a report that contains a description of the sediment and actions taken to address the cause of the deposition. Division staff may waive the requirement for a written report on a case-by-case basis. If the stream is named on the N.C. 303(d) list as impaired for sediment-related causes, the permittee may be required to perform additional monitoring, investigations or apply more stringent practices that determine that additional requirements are needed to assure compliance with the federal or state impaired waters criteria. |
| (b) Oil spills and releases of hazardous substances per item 1)(b) (5) above | <ul style="list-style-type: none"> Within 48 hours, an oral or electronic notification. The notification shall include information about the date, time, nature, volume and location of the spill or release. |
| (c) Anticipated bypasses (40 CFR 122.41(m)(2)) | <ul style="list-style-type: none"> A report at least ten days before the date of the bypass, if possible. The report shall include an evaluation of the anticipated quality and effect of the bypass. |
| (d) Unanticipated bypasses (40 CFR 122.41(m)(2)) | <ul style="list-style-type: none"> Within 24 hours, an oral or electronic notification. Within 7 calendar days, a report that includes an evaluation of the quality and effect of the bypass. |
| (e) Non-compliance with the conditions of this permit that may endanger health or the environment (40 CFR 122.41(f)(7)) | <ul style="list-style-type: none"> Within 24 hours, an oral or electronic notification. Within 7 calendar days, a report that contains a description of the non-compliance, and its causes, the period of non-compliance, including start date and time, and if the non-compliance has not been corrected, the anticipated time non-compliance is expected to continue, and steps taken or planned to reduce, eliminate, and prevent recurrence of the non-compliance. (40 CFR 122.41(f)(5)). Division staff may waive the requirement for a written report on a case-by-case basis. |

- PART I, SECTION G, ITEM (4) DRAW DOWN OF SEDIMENT BASINS FOR MAINTENANCE OR CLOSE OUT**
- Sediment basins and traps that receive runoff from drainage areas of one acre or more shall use outlet structures that withdraw water from the surface when these devices need to be drawn down for maintenance or close out unless this is infeasible. The circumstances in which it is not feasible to withdraw water from the surface shall be rare (for example, times with extended cold weather). Non-surface withdrawals from sediment basins shall be allowed only when all of the following criteria have been met:
- The E&S plan authority has been provided with documentation of the non-surface withdrawal and the specific time periods or conditions in which it will occur. The non-surface withdrawal shall not commence until the E&S plan authority has approved these items.
 - The non-surface withdrawal has been reported as an anticipated bypass in accordance with Part III, Section C, Item 2)(c) and (d) of this permit.
 - Dewatering discharges are treated with controls to minimize discharges of pollutants from stormwater that is removed from the sediment basin. Examples of appropriate controls include properly sited, designed and maintained dewatering tanks, weir tanks, and filtration systems.
 - Vegetated, upland areas of the sites or a properly designed stone pad is used to the extent feasible at the outlet of the dewatering treatment devices described in item (c) above.
 - Velocity dissipation devices such as check dams, sediment traps, and riprap are provided at the discharge points of all dewatering devices, and
 - Sediment removed from the dewatering treatment devices described in item (c) above is disposed of in a manner that does not cause deposition of sediment into waters of the United States.

NCG01 SELF-INSPECTION, RECORDKEEPING AND REPORTING EFFECTIVE: 04/01/19

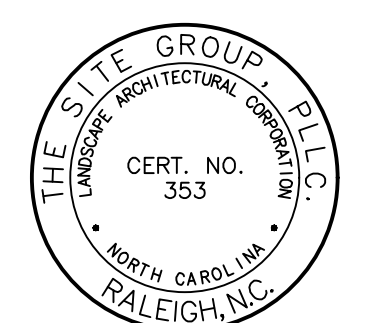

NC ENGINEERING LICENSE NO. P-0803

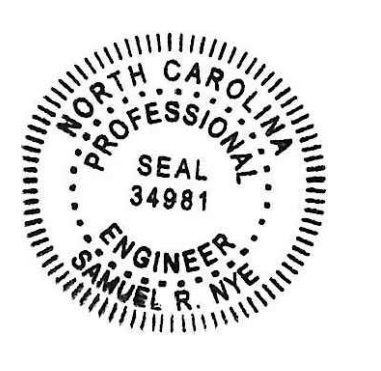

PRELIMINARY FOR REVIEW ONLY

THE SITE GROUP
 CIVIL ENGINEERS • LANDSCAPE ARCHITECTS
 THE SITE GROUP, PLLC
 111 JOHNSON ROAD
 RALEIGH, NC 27605-1136 USA
 Office: 919.835.4787
 Fax: 919.839.2255
 E-Mail: SRN@thesitegroup.net

CONSTRUCTION DRAWINGS FOR:
BARBEE ST. SUBDIVISION
 0 E. BARBEE STREET
 ZEBULON, NORTH CAROLINA

Drawn By: **WRR**
 Checked By: **SRN**

DATE:
 07 NOV 2022

CONSTRUCTION DRAWINGS

NPDES PLAN

Job Code: **SCBSZ**

Dwg No.
SITE 304

STANDARD UTILITY NOTES

- ALL MATERIALS & CONSTRUCTION METHODS SHALL BE IN ACCORDANCE WITH CITY OF RALEIGH DESIGN STANDARDS, DETAILS & SPECIFICATIONS (REFERENCE: CORPUD HANDBOOK, CURRENT EDITION).
- UTILITY SEPARATION REQUIREMENTS:
 - A DISTANCE OF 100' SHALL BE MAINTAINED BETWEEN SANITARY SEWER & ANY PRIVATE OR PUBLIC WATER SUPPLY SOURCE SUCH AS AN IMPOUNDED RESERVOIR USED AS A SOURCE OF DRINKING WATER. IF ADEQUATE LATERAL SEPARATION CANNOT BE ACHIEVED, FERROUS SANITARY SEWER PIPE SHALL BE SPECIFIED & INSTALLED TO WATERLINE SPECIFICATIONS. HOWEVER, THE MINIMUM SEPARATION SHALL NOT BE LESS THAN 25' FROM A PRIVATE WELL OR 50' FROM A PUBLIC WELL.
 - WHEN INSTALLING WATER &/OR SEWER MAINS, THE HORIZONTAL SEPARATION BETWEEN UTILITIES SHALL BE 10'. IF THIS SEPARATION CANNOT BE MAINTAINED DUE TO EXISTING CONDITIONS, THE VARIATION ALLOWED IS THE WATER MAIN IN A SEPARATE TRENCH WITH THE ELEVATION OF THE WATER MAIN AT LEAST 18" ABOVE THE TOP OF THE SEWER & MUST BE APPROVED BY THE PUBLIC UTILITIES DIRECTOR. ALL DISTANCES ARE MEASURED FROM OUTSIDE DIAMETER TO OUTSIDE DIAMETER.
 - WHERE IT IS IMPOSSIBLE TO OBTAIN PROPER SEPARATION, OR ANYTIME A SANITARY SEWER PASSES OVER A WATERMAIN, DIP MATERIALS OR STEEL ENCASUREMENT EXTENDED 10' ON EACH SIDE OF CROSSING MUST BE SPECIFIED & INSTALLED TO WATERLINE SPECIFICATIONS.
 - 5.0' MINIMUM HORIZONTAL SEPARATION IS REQUIRED BETWEEN ALL SANITARY SEWER & STORM SEWER FACILITIES, UNLESS DIP MATERIAL IS SPECIFIED FOR SANITARY SEWER.
 - MAINTAIN 18" MIN. VERTICAL SEPARATION AT ALL WATERMAIN & RCP STORM DRAIN CROSSINGS; MAINTAIN 24" MIN. VERTICAL SEPARATION AT ALL SANITARY SEWER RCP STORM DRAIN CROSSINGS. WHERE ADEQUATE SEPARATIONS CANNOT BE ACHIEVED, SPECIFY DIP MATERIALS & A CONCRETE CRADLE HAVING 6" MIN. CLEARANCE (PER CORPUD DETAILS W-41 & S-49).
 - ALL OTHER UNDERGROUND UTILITIES SHALL CROSS WATER & SEWER FACILITIES WITH 18" MIN. VERTICAL SEPARATION REQUIRED.
- ANY NECESSARY FIELD REVISIONS ARE SUBJECT TO REVIEW & APPROVAL OF AN AMENDED PLAN &/OR PROFILE BY THE CITY OF RALEIGH PUBLIC UTILITIES DEPARTMENT PRIOR TO CONSTRUCTION.
- CONTRACTOR SHALL MAINTAIN CONTINUOUS WATER & SEWER SERVICE TO EXISTING RESIDENCES & BUSINESSES THROUGHOUT CONSTRUCTION OF PROJECT. ANY NECESSARY SERVICE INTERRUPTIONS SHALL BE PRECEDED BY A 24 HOUR ADVANCE NOTICE TO THE CITY OF RALEIGH PUBLIC UTILITIES DEPARTMENT.
- 3.0' MINIMUM COVER IS REQUIRED ON ALL WATER MAINS & SEWER FORCE MAINS. 4.0' MINIMUM COVER IS REQUIRED ON ALL REUSE MAINS.
- IT IS THE DEVELOPER'S RESPONSIBILITY TO ABANDON OR REMOVE EXISTING WATER & SEWER SERVICES NOT BEING USED IN REDEVELOPMENT OF A SITE UNLESS OTHERWISE DIRECTED BY THE CITY OF RALEIGH PUBLIC UTILITIES DEPARTMENT. THIS INCLUDES ABANDONING TAP AT MAIN & REMOVAL OF SERVICE FROM ROW OR EASEMENT PER CORPUD HANDBOOK PROCEDURE.
- INSTALL 1/2" COPPER WATER SERVICES WITH METERS LOCATED AT ROW OR WITHIN A 2'X2' WATERLINE EASEMENT IMMEDIATELY ADJACENT. NOTE: IT IS THE APPLICANT'S RESPONSIBILITY TO PROPERLY SIZE THE WATER SERVICE FOR EACH CONNECTION TO PROVIDE ADEQUATE FLOW & PRESSURE.
- INSTALL 4" PVC SEWER SERVICES @ 1.0% MINIMUM GRADE WITH CLEANOUTS LOCATED AT ROW OR EASEMENT LINE & SPACED EVERY 75 LINEAR FEET MAXIMUM.
- PRESSURE REDUCING VALVES ARE REQUIRED ON ALL WATER SERVICES EXCEEDING 80 PSI. BACKWATER VALVES ARE REQUIRED ON ALL SANITARY SEWER SERVICES HAVING BUILDING DRAINS LOWER THAN 1.0' ABOVE THE NEXT UPSTREAM MANHOLE.
- ALL ENVIRONMENTAL PERMITS APPLICABLE TO THE PROJECT MUST BE OBTAINED FROM NCDOW, USACE &/OR FEMA FOR ANY RIPARIAN BUFFER, WETLAND &/OR FLOODPLAIN IMPACTS (RESPECTIVELY) PRIOR TO CONSTRUCTION.
- NCDOT / RAILROAD ENCROACHMENT AGREEMENTS ARE REQUIRED FOR ANY UTILITY WORK (INCLUDING MAIN EXTENSIONS & SERVICE TAPS) WITHIN STATE OR RAILROAD ROW PRIOR TO CONSTRUCTION.
- GREASE INTERCEPTOR / OIL WATER SEPARATOR SIZING CALCULATIONS & INSTALLATION SPECIFICATIONS SHALL BE APPROVED BY THE CORPUD FOG PROGRAM COORDINATOR PRIOR TO ISSUANCE OF A BUILDING PERMIT. CONTACT TIM BEASLEY AT (919) 996-2334 OR TIMOTHY.BEASLEY@RALEIGHNC.GOV FOR MORE INFORMATION.
- CROSS-CONNECTION CONTROL PROTECTION DEVICES ARE REQUIRED BASED ON DEGREE OF HEALTH HAZARD INVOLVED AS LISTED IN APPENDIX-B OF THE RULES GOVERNING PUBLIC WATER SYSTEMS IN NORTH CAROLINA. THESE GUIDELINES ARE THE MINIMUM REQUIREMENTS. THE DEVICES SHALL MEET AMERICAN SOCIETY OF SANITARY ENGINEERING (ASSE) STANDARDS OR BE ON THE UNIVERSITY OF SOUTHERN CALIFORNIA APPROVAL LIST. THE DEVICES SHALL BE INSTALLED AND TESTED (BOTH INITIAL AND PERIODIC TESTING THEREAFTER) IN ACCORDANCE WITH THE MANUFACTURER'S RECOMMENDATIONS OR THE LOCAL CROSS-CONNECTION CONTROL PROGRAM, WHICHEVER IS MORE STRINGENT. CONTACT JOANIE HARTLEY AT (919) 996-5923 OR JOANIE.HARTLEY@RALEIGHNC.GOV FOR MORE INFORMATION.

GENERAL NOTES

- ALL MATERIALS AND METHODS OF CONSTRUCTION SHALL BE IN ACCORDANCE WITH THE TOWN OF ZEBULON AND THE STATE OF NORTH CAROLINA STANDARDS AND SPECIFICATIONS.
- CONTRACTOR SHALL HAVE NORTH CAROLINA ONE CALL (811) LOCATE ALL EXISTING UTILITIES PRIOR TO BEGINNING CONSTRUCTION.
- CONTRACTOR SHALL VERIFY THE LOCATION AND DEPTH OF ALL EXISTING UTILITIES AND NOTIFY THE ENGINEER OF ANY DISCREPANCIES OR CONFLICTS PRIOR TO BEGINNING CONSTRUCTION.
- BOUNDARY AND SURVEY INFORMATION IS TAKEN FROM A SURVEY BY ANGLE RIGHT LAND SURVEYING, PLLC DATED JUNE 1, 2022.
- ALL CONSTRUCTION SHALL CONFORM TO A.D.A. STANDARDS.
- NO PORTION OF THE PROPERTY IS LOCATED WITHIN A FEMA AE FLOOD ZONE BASED ON THE MAP #3720270500J MAP REVISED MAY 6, 2006.

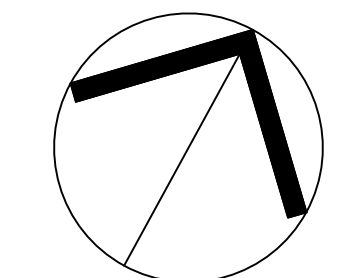

NORTH
UTILITY
PLAN

SCALE: 1" = 40' (DRAWING SCALED FOR 24x36 INCH PLOTS)

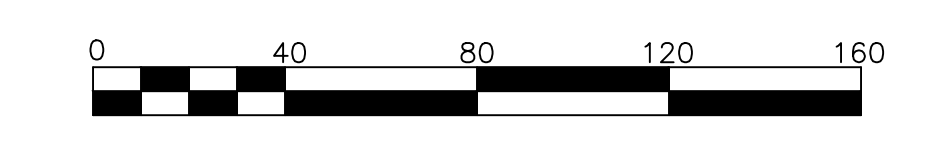

NC ENGINEERING
LICENSE NO. P-5803



PRELIMINARY FOR
REVIEW ONLY

THE SITE GROUP
CIVIL ENGINEERS • LANDSCAPE ARCHITECTS
THE SITE GROUP, PLLC
1111 700th St
Raleigh, NC 27605-1136 USA
Office: 919.835.4787
Fax: 919.835.2255
E-Mail: SRN@thesitegroup.net

CONSTRUCTION DRAWINGS FOR:
BARBEE ST. SUBDIVISION
0 E. BARBEE STREET
ZEBULON, NORTH CAROLINA

Drawn By: **WRR**
Checked By: **SRN**

DATE:
07 NOV 2022

CONSTRUCTION DRAWINGS

UTILITY PLAN

Job Code: **SCBSZ**

Dwg No.
**SITE
400**

Copyright © 2022, The Site Group, PLLC. ALL RIGHTS RESERVED.

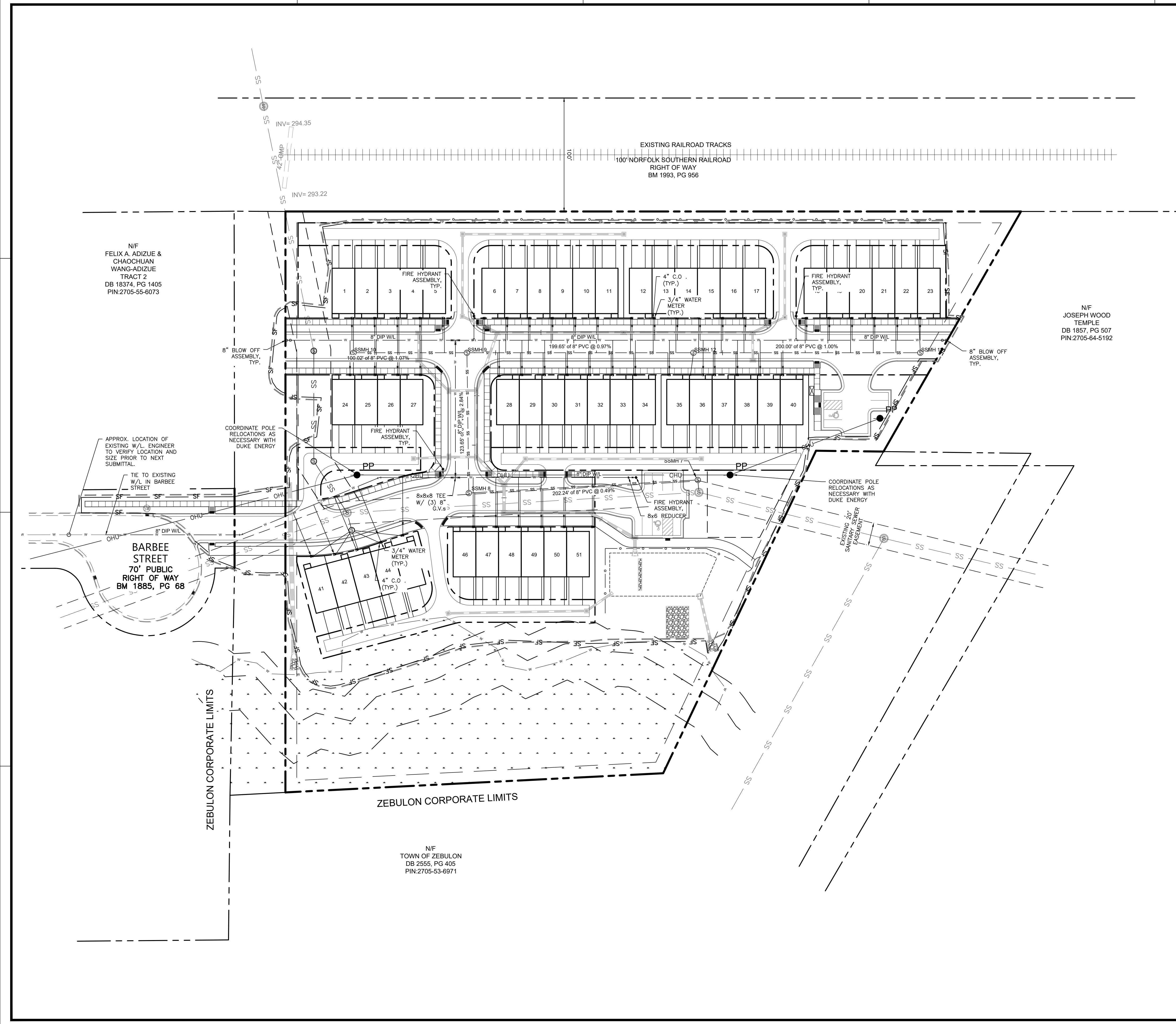

N/F
FELIX A. ADIZUE &
CHAOCHUAN
WANG-ADIZUE
TRACT 2
DB 18374, PG 1405
PIN:2705-55-6073

N/F
JOSEPH WOOD
TEMPLE
DB 1857, PG 507
PIN:2705-64-5192

BARBEE
STREET
70' PUBLIC
RIGHT OF WAY
BM 1885, PG 68

N/F
TOWN OF ZEBULON
DB 2555, PG 405
PIN:2705-53-6971

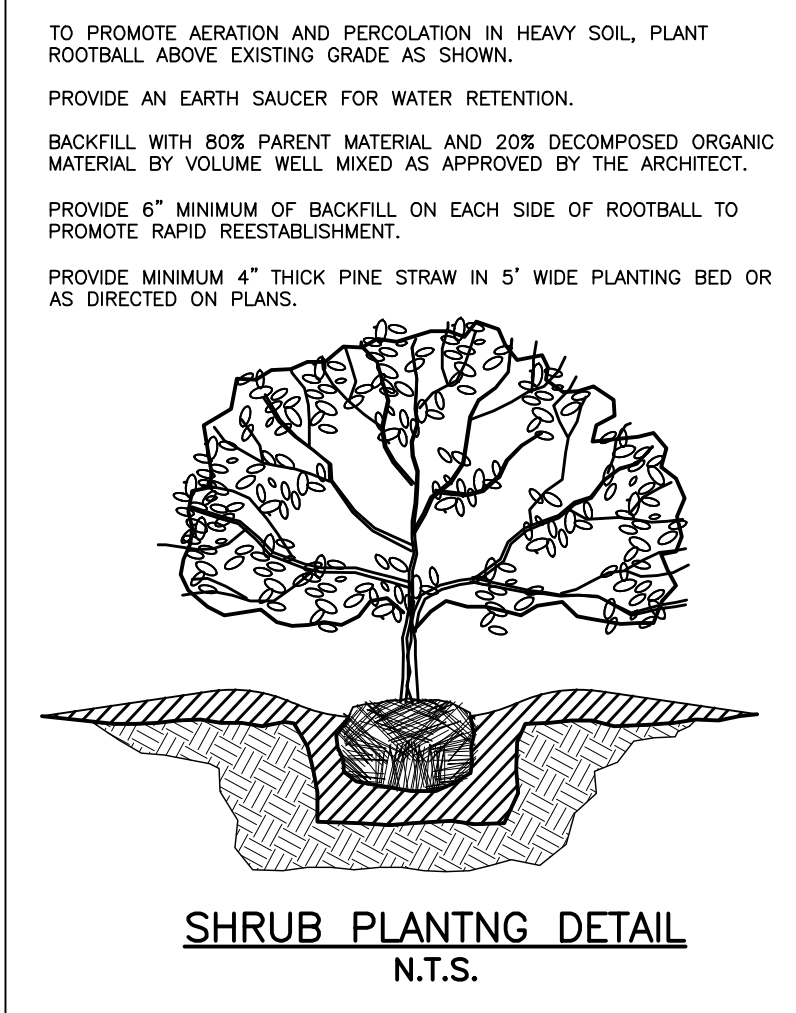
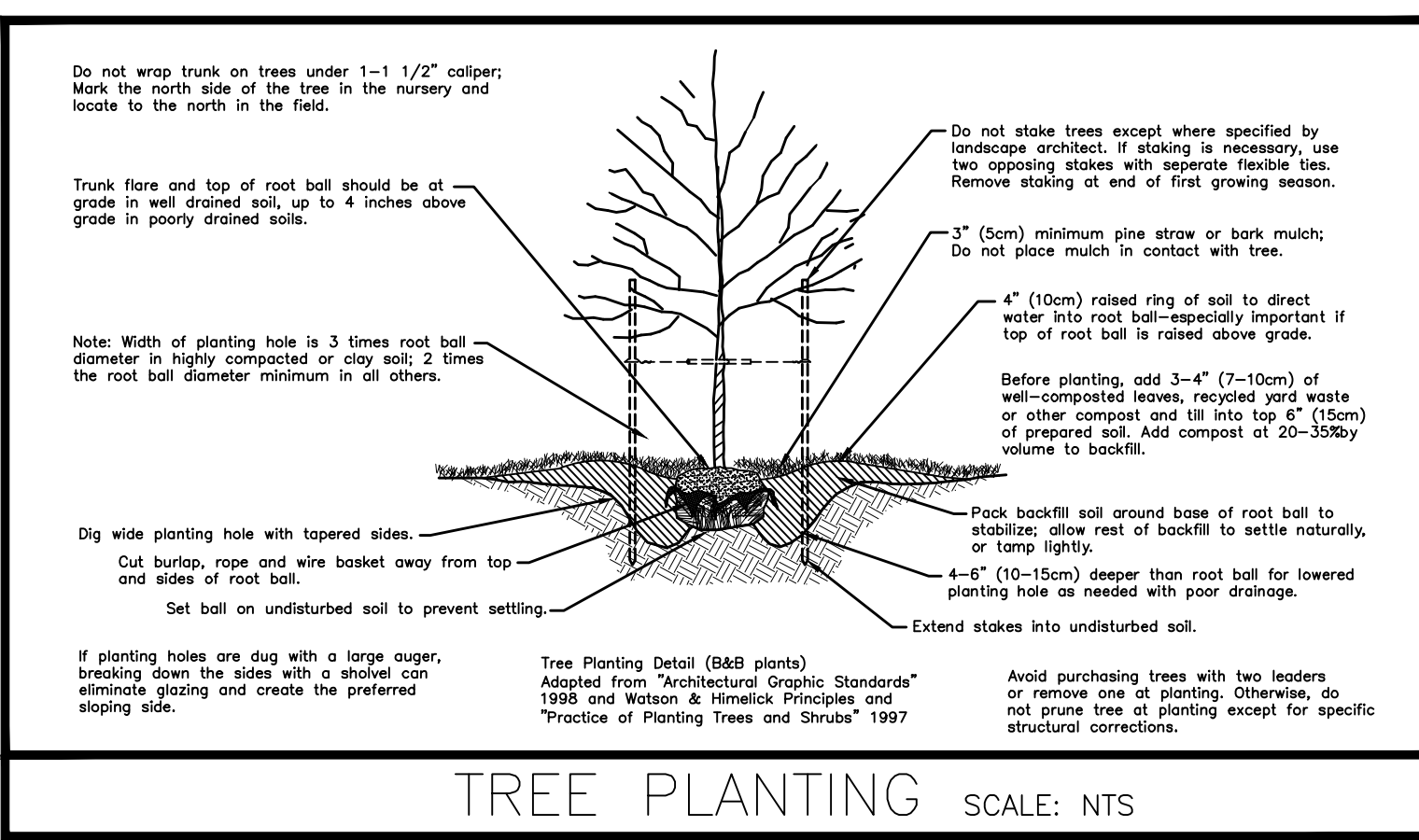
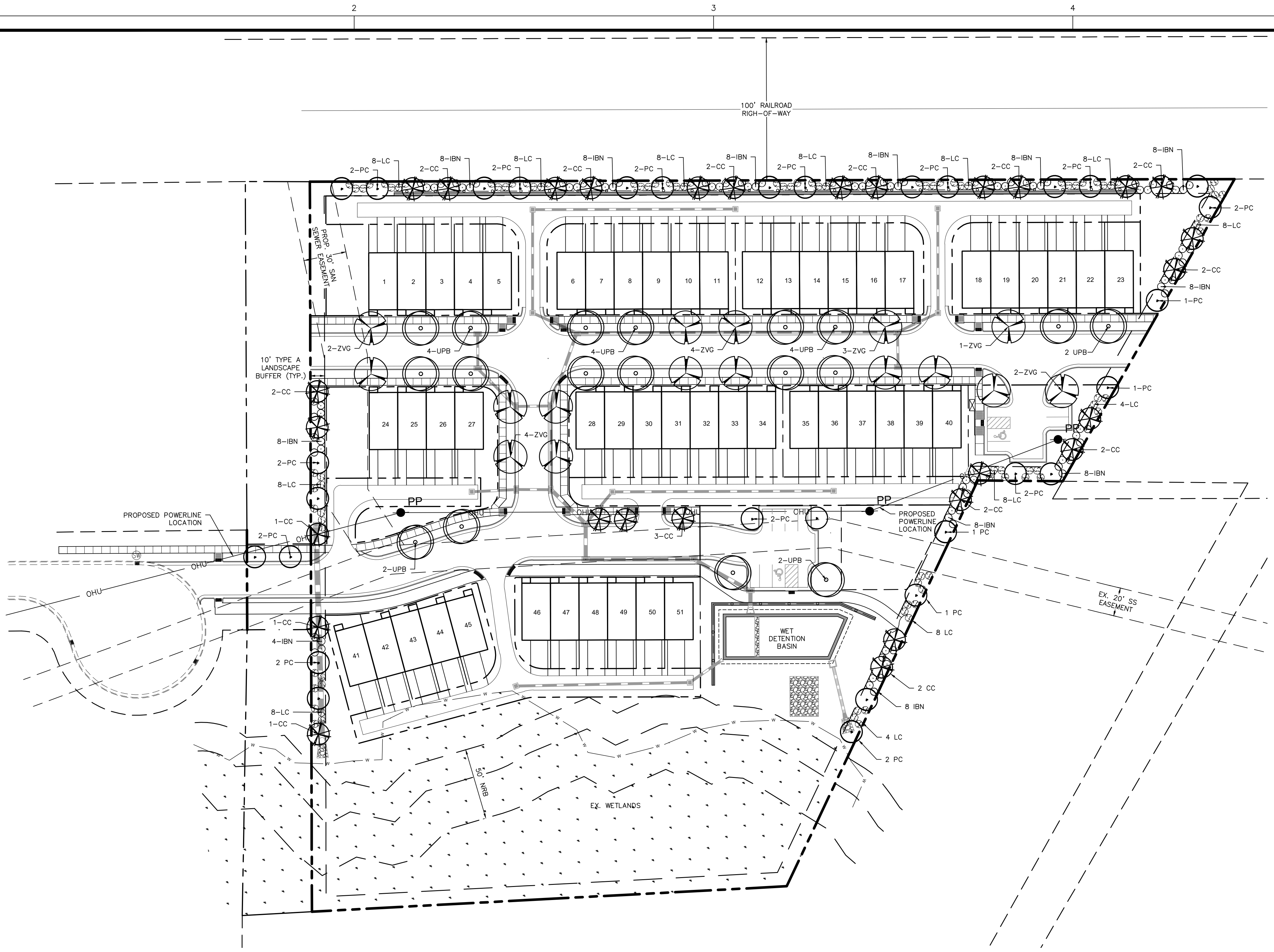

OVERALL PLANT LIST

KEY	QTY	BOTANICAL NAME	COMMON NAME	HEIGHT	SIZE	ROOT	REMARKS
CANOPY TREES							
UPB	18	ULMUS PARVIFOLIA 'BOSQUE'	BOSQUE CHINESE ELM	10'	3" CAL.	B&B	MATCHING
ZVG	16	ZELKOVA SERRATA 'VILLAGE GREEN'	VILLAGE GREEN ZELKOVA	10'	3" CAL.	B&B	MATCHING
UNDERSTORY TREES							
CC	28	CERCIS CANADENSIS	EASTERN REDBUD	8' MIN.	2" CAL.	B&B	MATCHING
PC	30	PISTACHIA CHINENSIS	CHINESE PISTACHE	8' MIN.	2" CAL.	B&B	MATCHING
SHRUBS							
IBN	92	ILEX CORNUTA 'BURFORDII NANA'	DWARF BURFORD HOLLY	24" HT. MIN.	5 GAL.	CONT.	MATCHING
LC	96	LOROPETALUM CHINENSE 'EVER RED'	EVER RED LOROPETALUM	24" HT. MIN.	5 GAL.	CONT.	MATCHING

PLANTING NOTES:
 LOCATE PLANTS AND PLANTING BEDS BY USING SCALED DIMENSIONS FROM STREET, PROPERTY LINES, BACK OF CURB, BUILDINGS, WALLS, ETC. ALL PLANTS SHALL MEET OR EXCEED THE MINIMUM STANDARDS SET BY THE U.S.D.A. FOR NURSERY STOCK SPONSORED BY THE AMERICAN ASSOCIATION OF NURSERMEN, INC., WASHINGTON, D.C. NO SUBSTITUTIONS SHALL BE PERMITTED WITHOUT WRITTEN APPROVAL FROM THE OWNER AND/OR THE LANDSCAPE ARCHITECT.
SYMBOLS: B&B = BALLED & BURLAPPED; B.R. = BARE ROOT; CONT. = CONTAINER, O.C. = ON-CENTER, (R) = TO REMAIN
MULCH: MULCH ALL BED AREAS WITH HARDWOOD MULCH TO A DEPTH OF 3".
NOTE:
 1. ANY TREES IN SIGHT TRIANGLES WILL BE LIMBED UP TO A HEIGHT OF 8'. ALL SHRUBS LOCATED IN SIGHT TRIANGLES WILL BE MAINTAINED BELOW 2'.
 2. ALL SHRUB SPECIES SHALL REACH A MINIMUM OF 36" WITHIN THREE YEARS OF INSTALLATION.

LANDSCAPE MAINTENANCE PLAN:

THE OWNERS OF THE PROPERTY AND THEIR AGENTS, HEIRS OR ASSIGNS SHALL BE RESPONSIBLE FOR THE INSTALLATION, PRESERVATION AND MAINTENANCE OF ALL PLANTINGS AND PHYSICAL FEATURES SHOWN ON THIS PLAN. THE OWNERS SHALL BE RESPONSIBLE FOR ANNUAL MAINTENANCE OF THE VEGETATION TO INCLUDE BUT NOT LIMITED TO:

- FERTILIZATION:** FERTILIZE LAWNS TWICE PER YEAR (FEBRUARY 15-MARCH 15 AND AGAIN SEPTEMBER 1-OCTOBER 31) ACCORDING TO SOIL TEST. FERTILIZE WARM SEASON GRASSES ONCE DURING THE GROWING SEASON PER SOIL TEST.
- PRUNING:** PRUNING SHALL BE LIMITED TO REMOVAL OF DEAD WOOD OR BRANCHES FOR TREES OR FOR SIGHT DISTANCES/SAFETY REASONS. THE ANSI A300 STANDARDS SHOULD BE ADHERED TO. THE PRUNING OF SHRUBS SHALL BE LIMITED TO THE PRUNING NECESSARY TO MAINTAIN THE NATURAL SHAPE OF THE PLANT EXCEPT FOR SHEARED HEDGES.
- PEST CONTROL:** PRE-EMERGENT WEED CONTROL FOR SHRUB BEDS MAY BE APPLIED IN FEBRUARY. CHEMICAL TREATMENT FOR INSECT INFESTATION AND DISEASE MAY BE APPLIED AND SHALL BE SPECIFIC TO THE PROBLEM.
- MULCHING:** MULCHING SHALL BE MAINTAINED AT A DEPTH OF 2-3" IN SHRUB BEDS. MULCH SHALL BE REAPPLIED EVERY TWO YEARS, AS NECESSARY TO MAINTAIN THE AVERAGE DEPTH OF THE PLANT BED.
- MOWING:** PRIMARY FESCUE LAWNS SHALL BE MAINTAINED AT A HEIGHT OF 3" AND SHALL BE MOWED APPROXIMATELY 30 TIMES PER YEAR. SECONDARY TURF AREAS MAY BE MAINTAINED HIGHER AND LESS FREQUENTLY. WARM SEASON GRASSES SHALL BE MOWED AS NEEDED DURING THE GROWING SEASON TO MAINTAIN THE RECOMMENDED HEIGHT OF THE SPECIES OF TURF GRASS.
- PLANT PROTECTION:** AVOID EXCESS INTRUSION INTO THE ROOT ZONE AREA OF ESTABLISHED PLANTINGS.
- WATERING:** IF ANY IRRIGATION SYSTEM IS UTILIZED, THE SYSTEM SHALL BE REGULATED TO PROVIDE APPROXIMATELY 1" OF RAINFALL PER WEEK DURING THE GROWING SEASON. (PENDING TOWN OF ZEBULON WATER/IRRIGATION SUPPLIES)
- PLANT REPLACEMENT:** ANY REQUIRED PLANTING, WHICH IS REMOVED OR DIES AFTER DATE OF PLANTING SHALL BE REPLACE DURING THE NEXT PLANTING SEASON. ALSO, ANY TREE IN A TREE PRESERVATION AREA WHICH IS REMOVED OR DIES SHALL BE REPLACED DURING THE NEXT PLANTING SEASON.

REMOVAL OF DISEASE INFESTED MATERIAL SHALL BE ALLOWED SO LONG AS REQUIRED SHRUBS ARE REPLACED AT THE REQUIRED RATES AND SIZES.
 FAILURE TO MAINTAIN REQUIRED LANDSCAPE AREAS SHALL CONSTITUTE A VIOLATION OF THIS UDO ENFORCEABLE UNDER THE PROVISIONS OF SECTION 10-ENFORCEMENT.

LANDSCAPE REQUIREMENTS:

- THE SITE SHALL BE STABILIZED AND SEEDED PRIOR TO THE ISSUANCE OF A CERTIFICATE OF OCCUPANCY.
- ALL MECHANICAL EQUIPMENT, WASTE DISPOSAL FACILITIES, AND VEHICULAR USE AREAS (DRIVES AND PARKING) SHALL BE SCREENED FROM PUBLIC VIEW.
- ALL ABOVE GROUND UTILITY EQUIPMENT AND FACILITIES ASSOCIATED WITH ON-SITE ELECTRIC, CABLE, TELEPHONE, GAS OR OTHER SIMILAR UTILITY SHALL BE LOCATED IN THE SIDE OF REAR YARD AREA OF THE SITE AND SCREENED, TO THE EXTENT POSSIBLE, WITH EVERGREEN PLANTINGS. PLANTINGS SHALL ALLOW FOR A MINIMUM OF 5' CLEARANCE AROUND THE STRUCTURE TO ALLOW FOR ACCESS. ADDITIONALLY, ANY SIDE OF THE STRUCTURE HAVING A DOOR OR LOCK, THE PLANTINGS SHALL ALLOW FOR A 10' CLEARANCE. THE AMOUNT OF CLEARANCE SHALL ACCOUNT FOR THE SIZE OF THE PLANT MATERIAL AT MATURITY.
- THE SIZE OF THE PLANTING AREA AND SIZE OF PLANT MATERIAL AT MATURITY SHALL ALLOW FOR A 2.5' BUMPER OVERHANG FROM THE BACK OF CURB.
- NO TREE SHALL BE LOCATED WITHIN A ROADWAY RIGHT OF WAY OR WITHIN 5' OF A SIDEWALK AND WITHIN 20' OF A LIGHTING LOCATION.
- ALL SHRUBS INSTALLED AS VEHICULAR USE SCREENING WILL BE MAINTAINED AS A CONTINUOUS HEDGE AT A MINIMUM HEIGHT OF 36 INCHES.
- WHERE EXISTING OR PROPOSED VEGETATION FAILS TO FUNCTION ADEQUATELY AS REQUIRED, THE TOWN OF ZEBULON SITE INSPECTOR RESERVES THE RIGHT TO REQUIRE SUPPLEMENTAL PLANTINGS IN ADDITION TO THOSE SHOWN ON THE LANDSCAPE PLAN BASED ON ACTUAL FIELD CONDITIONS.
- UPON ESTABLISHMENT OF FINISHED GRADES AND PRIOR TO BEGINNING INSTALLATION OF ANY TREES, A SOIL AMENDMENT SCHEDULE FOR ALL TREE PLANTINGS SHALL BE PREPARED BY A CERTIFIED LANDSCAPE ARCHITECT AND BE PROVIDED TO THE TOWN OF ZEBULON PLANNING DEPARTMENT.
- PRIOR TO THE ISSUANCE OF A CERTIFICATE OF OCCUPANCY, A CERTIFIED STATEMENT SHALL BE PROVIDED TO CITY STAFF SITE INSPECTOR ATTESTING TO THE FACT THAT THE SOIL AMENDMENT SCHEDULE WAS FOLLOWED AS SPECIFIED IN THE APPROVED SITE AND/OR SUBDIVISION PLAN. THIS STATEMENT SHALL BE CERTIFIED BY A REGISTERED LANDSCAPE ARCHITECT, CERTIFIED ARBORIST, OR OTHER SPECIALIST AS DETERMINED ACCEPTABLE BY THE PLANNING DIRECTOR.
- THE PROPERTY OWNER OR DEVELOPER SHALL PROVIDE FOR CONTINUOUS MAINTENANCE OF THE LANDSCAPE AREAS AFTER OCCUPANCY OF THE BUILDING. THE PROPERTY OWNER SHALL ENSURE THAT PERFORMANCE CRITERIA WITHIN THIS ORDINANCE AND/OR INCLUDED ON THE APPROVED SITE AND/OR SUBDIVISION PLAN ARE MET. FAILURE TO CORRECT DEFICIENCIES IN A TIMELY MANNER SHALL RESULT IN A CITATION FOR VIOLATION OF THIS ORDINANCE IN ACCORDANCE WITH CHAPTER 11.
- ALL FOUNDATION PLANTINGS SHALL BE DESIGNED TO TOWN OF ZEBULON UDO SECTION REQUIREMENTS. THE TOWN OF ZEBULON SITE INSPECTOR RESERVES THE RIGHT TO REQUIRE ADDITIONAL PLANTINGS BASED ON ACTUAL FIELD CONDITIONS.
- ALL PLANTINGS WITHIN THE SIGHT DISTANCE TRIANGLES MUST BE 30 INCHES OR LESS IN HEIGHT OR MUST BE LIMBED UP TO PROVIDE 8' FROM THE LOWEST LIMBS TO THE CURB LINE ELEVATION OR THE NEAREST TRAVEL WAY IF NO CURBING EXISTS.

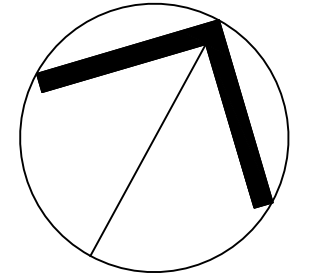

NORTH
 LANDSCAPE
 PLAN

SCALE: 1" = 40' (DRAWING SCALED FOR 24x36 INCH PLOTS)

THE SITE GROUP, PLLC
 LANDSCAPE ARCHITECTURE COMPANY
 CERT. NO. 353
 NORTH CAROLINA
 RALEIGH, NC

NC ENGINEERING
 LICENSE NO. P-0803

THE SITE GROUP, PLLC
 1419
 RANDON D. WOODS

PRELIMINARY
 FOR REVIEW ONLY

THE SITE GROUP
 CIVIL ENGINEERS • LANDSCAPE ARCHITECTS

THE SITE GROUP, PLLC
 111 S. COLONIAL BLVD.
 RALEIGH, NC 27605-1136 USA
 Office: 919.835.4787
 Fax: 919.839.2255
 E-Mail: SRN@thesitegroup.net

CONSTRUCTION DRAWINGS FOR:
BARBEE ST. SUBDIVISION
 0 E. BARBEE STREET
 ZEBULON, NORTH CAROLINA

Drawn By: WRR
 Checked By: SRN

DATE:
 07 NOV 2022

CONSTRUCTION
 DRAWING

LANDSCAPE
 PLAN

Job Code: SCBSZ

Dwg No.
SITE 500

Copyright © 2022 The Site Group, PLLC. ALL RIGHTS RESERVED.

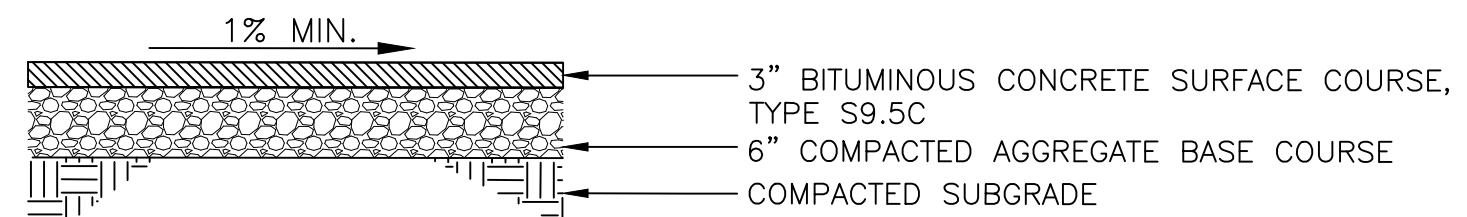

LIGHT DUTY ASPHALT PAVEMENT

N.T.S.

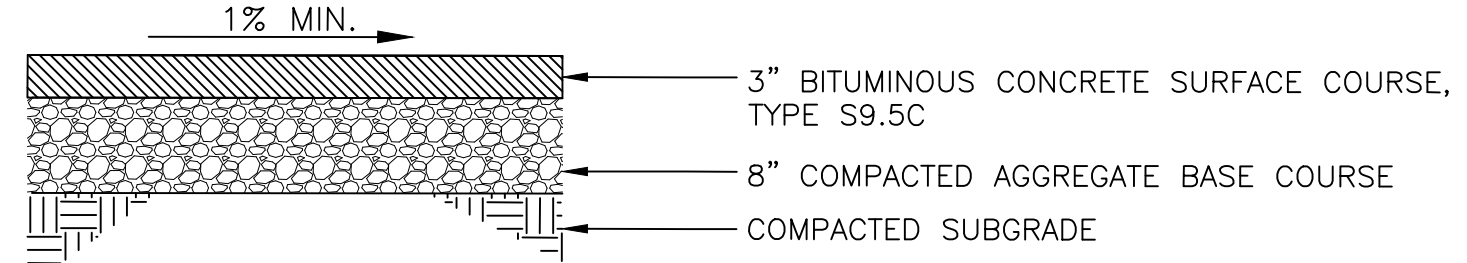

HEAVY DUTY ASPHALT PAVEMENT

N.T.S.

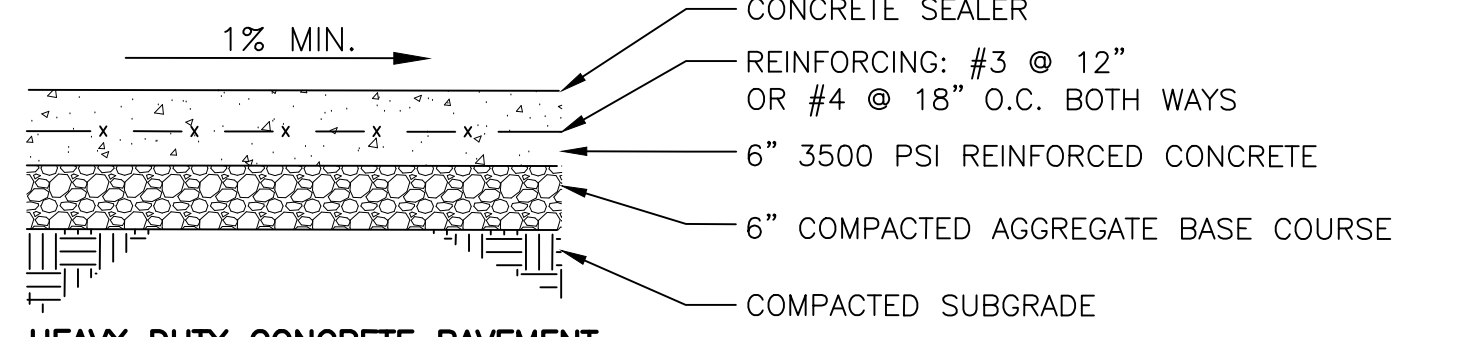

HEAVY DUTY CONCRETE PAVEMENT

TYPICAL PAVING SECTIONS
N.T.S.

NOTE:
FINAL PAVEMENT SECTIONS TO BE REVIEWED AND APPROVED BY
GEOTECHNICAL ENGINEER OF RECORD PRIOR TO CONSTRUCTION.

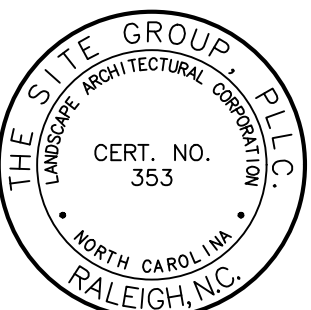

NC ENGINEERING
LICENSE NO. P-0803



PRELIMINARY FOR
REVIEW ONLY

THE SITE GROUP
CIVIL ENGINEERS • LANDSCAPE ARCHITECTS
THE SITE GROUP, PLLC.
10000 NC 27608-1136 USA
Raleigh, NC Office: 919.835.4787
Fax: 919.839.2255
E Mail: SRN@thesitegroup.net

CONSTRUCTION DRAWINGS FOR:
BARBEE ST. SUBDIVISION
0 E. BARBEE STREET
ZEBULON, NORTH CAROLINA

Drawn By: **WRR**
Checked By: **SRN**

DATE:
07 NOV 2022

CONSTRUCTION
DRAWING

SITE
DETAILS

Job Code: **SCBSZ**

Dwg No.
**SITE
700**

Copyright © 2022 The Site Group, PLLC. ALL RIGHTS RESERVED

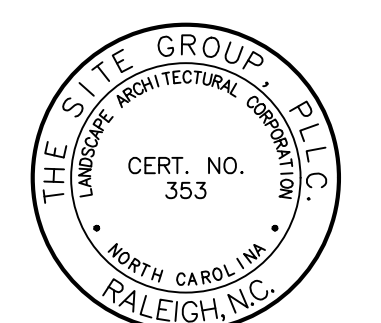
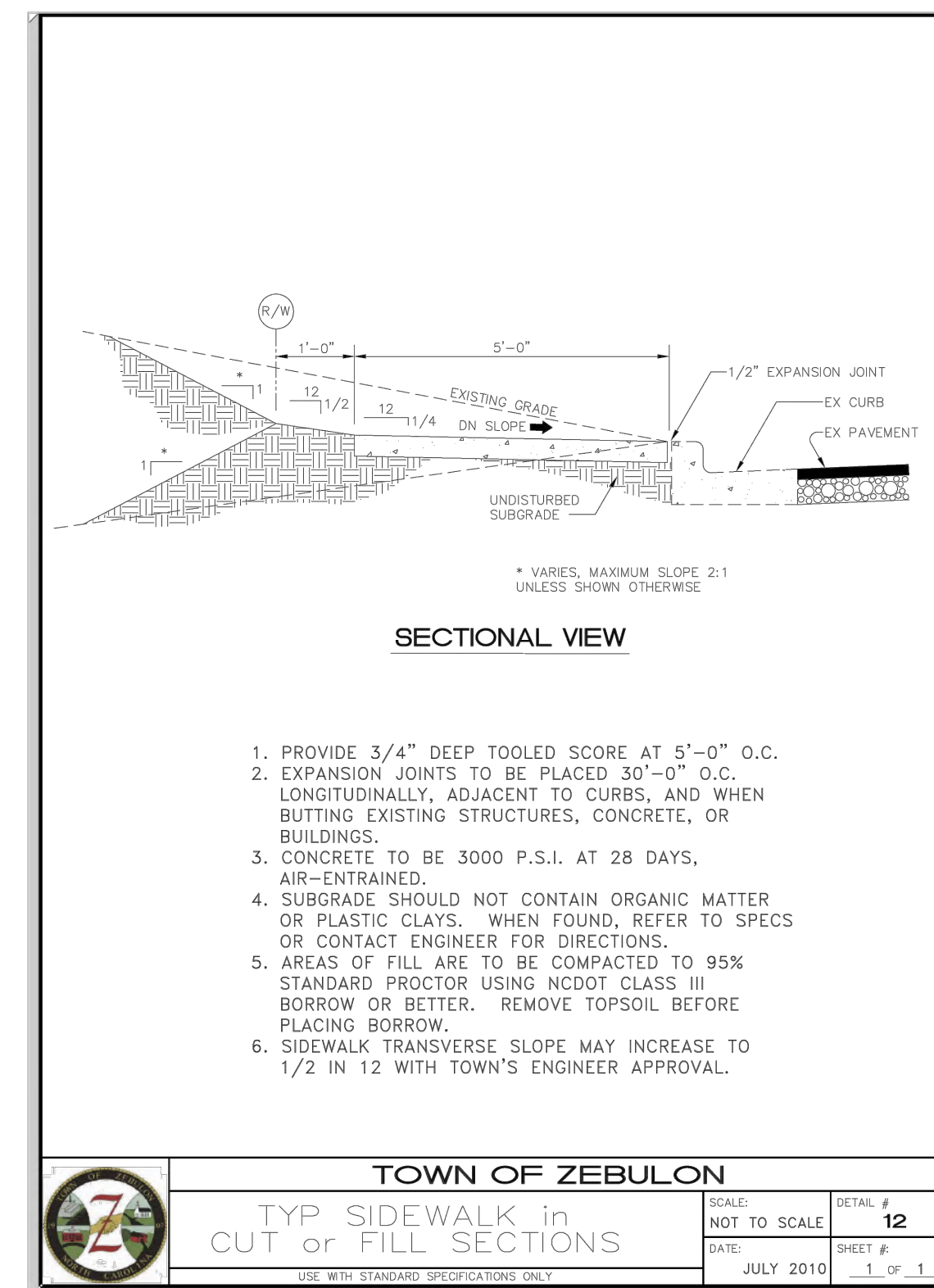
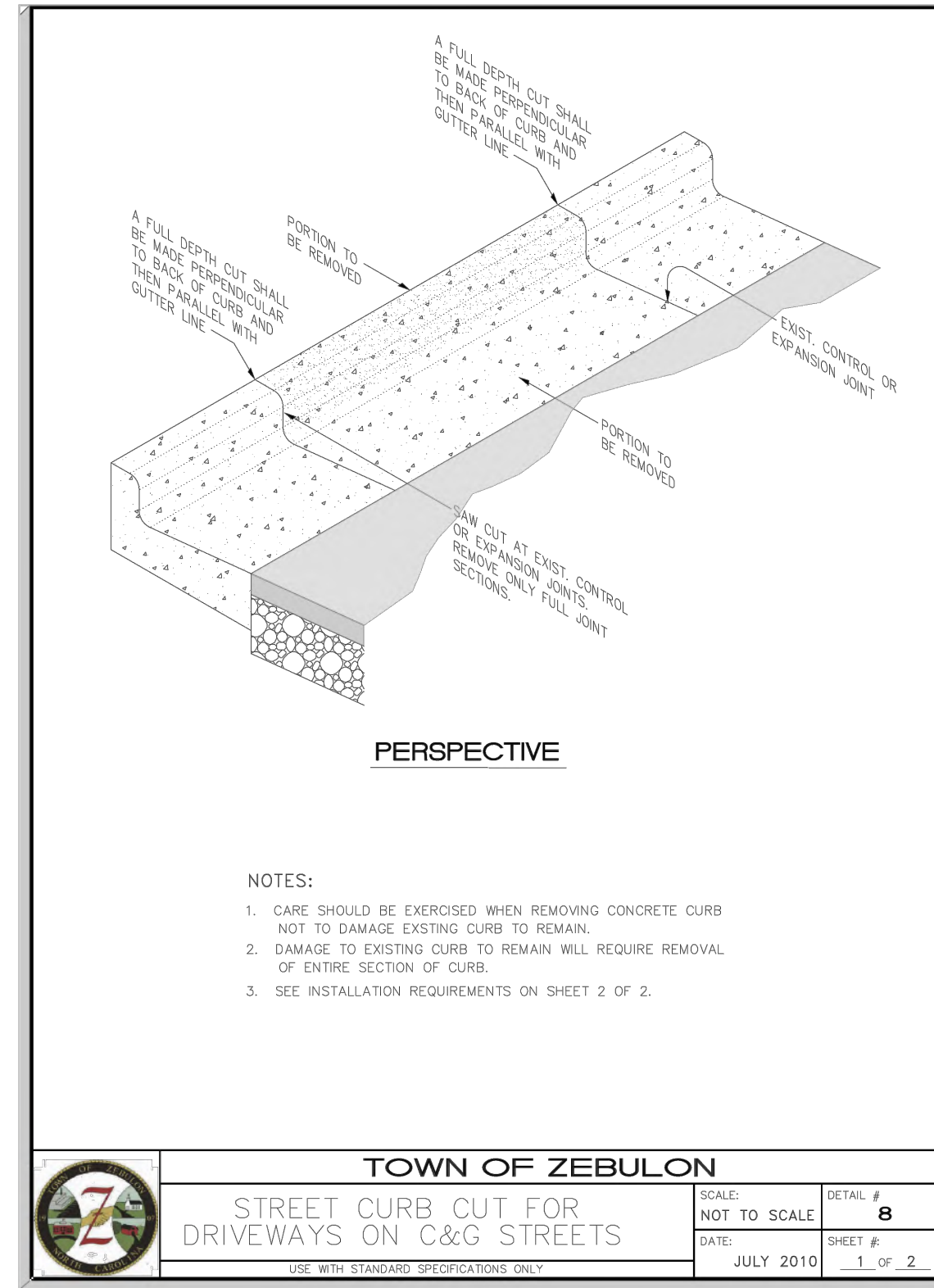
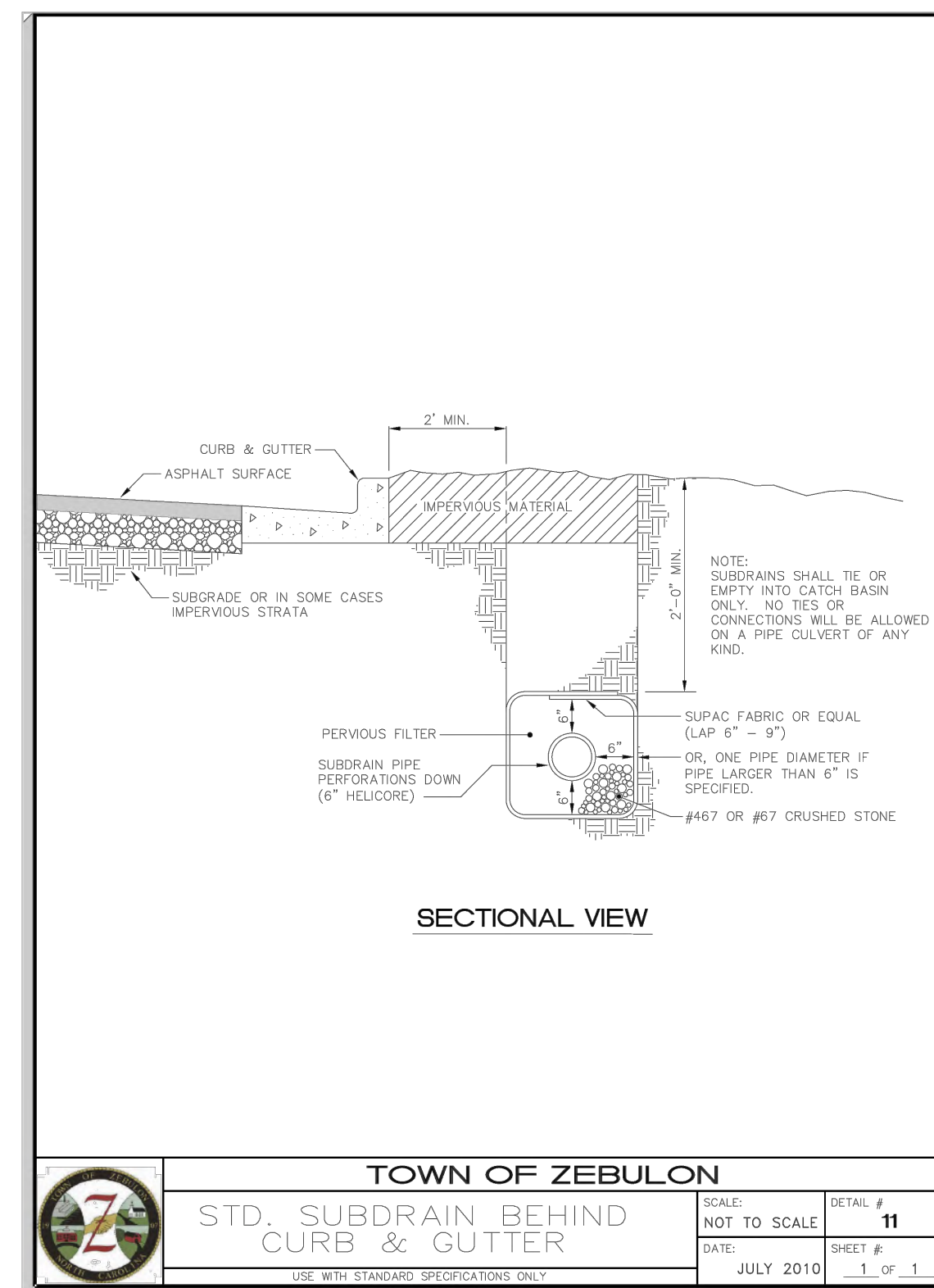
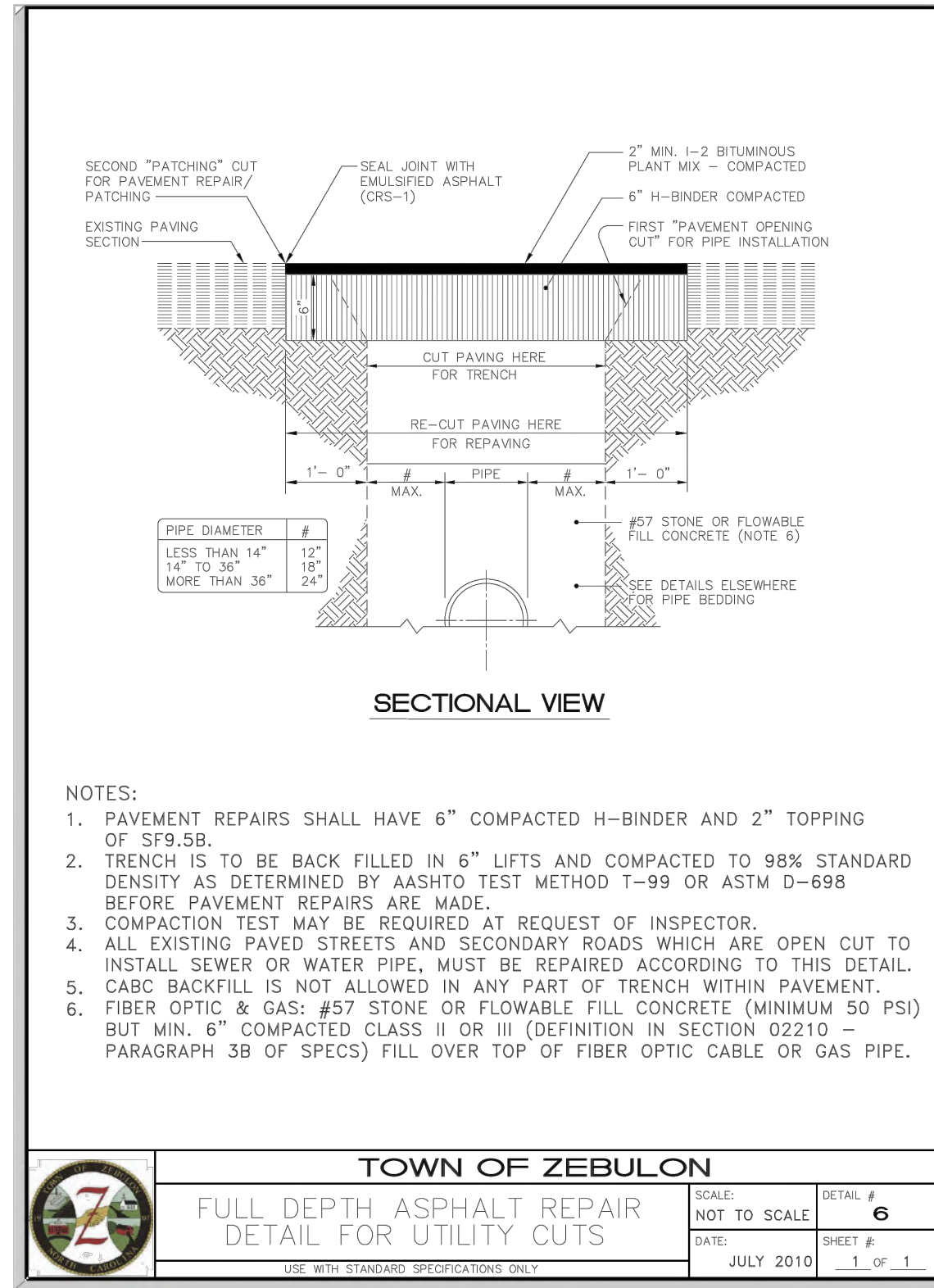
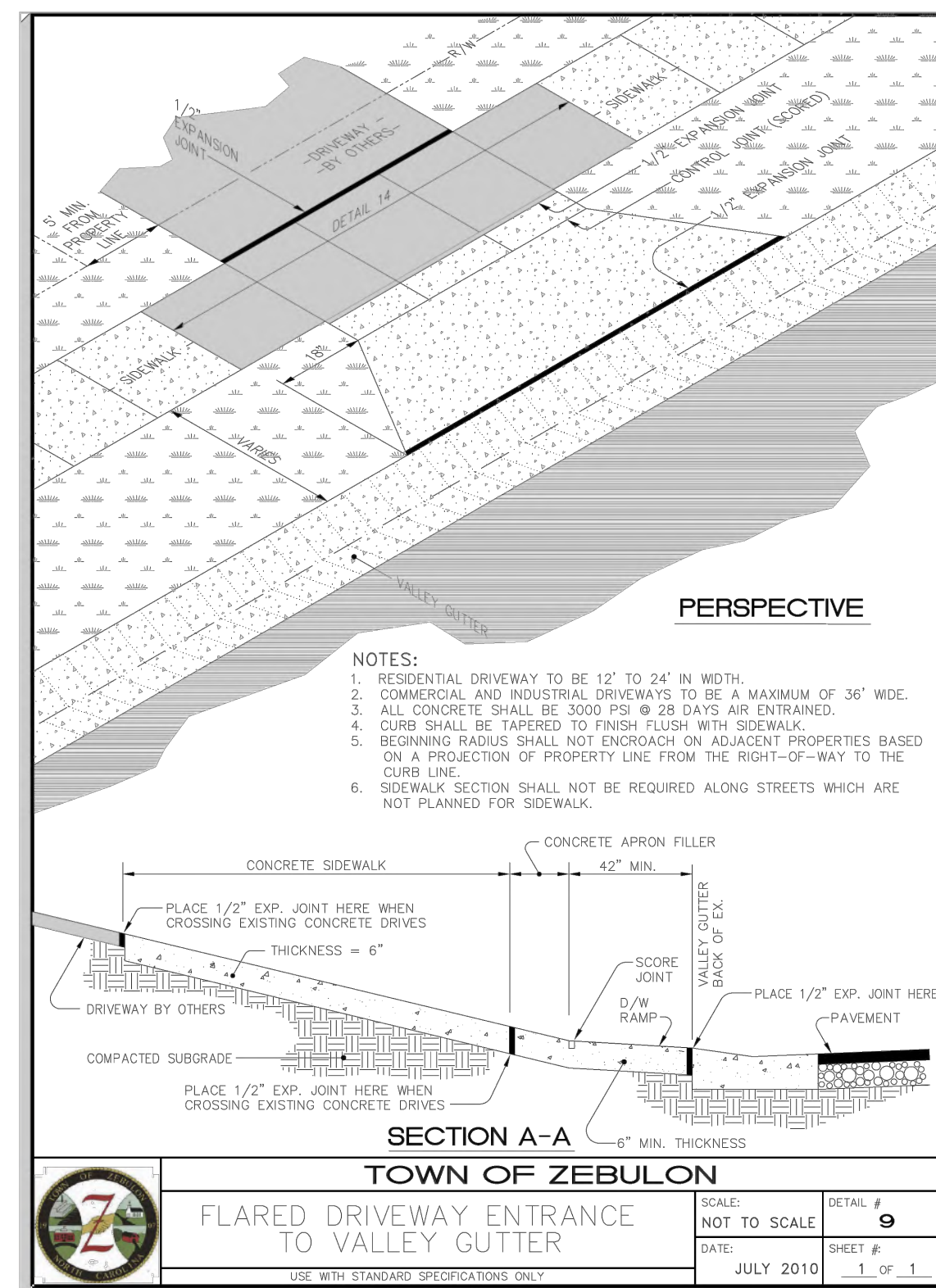
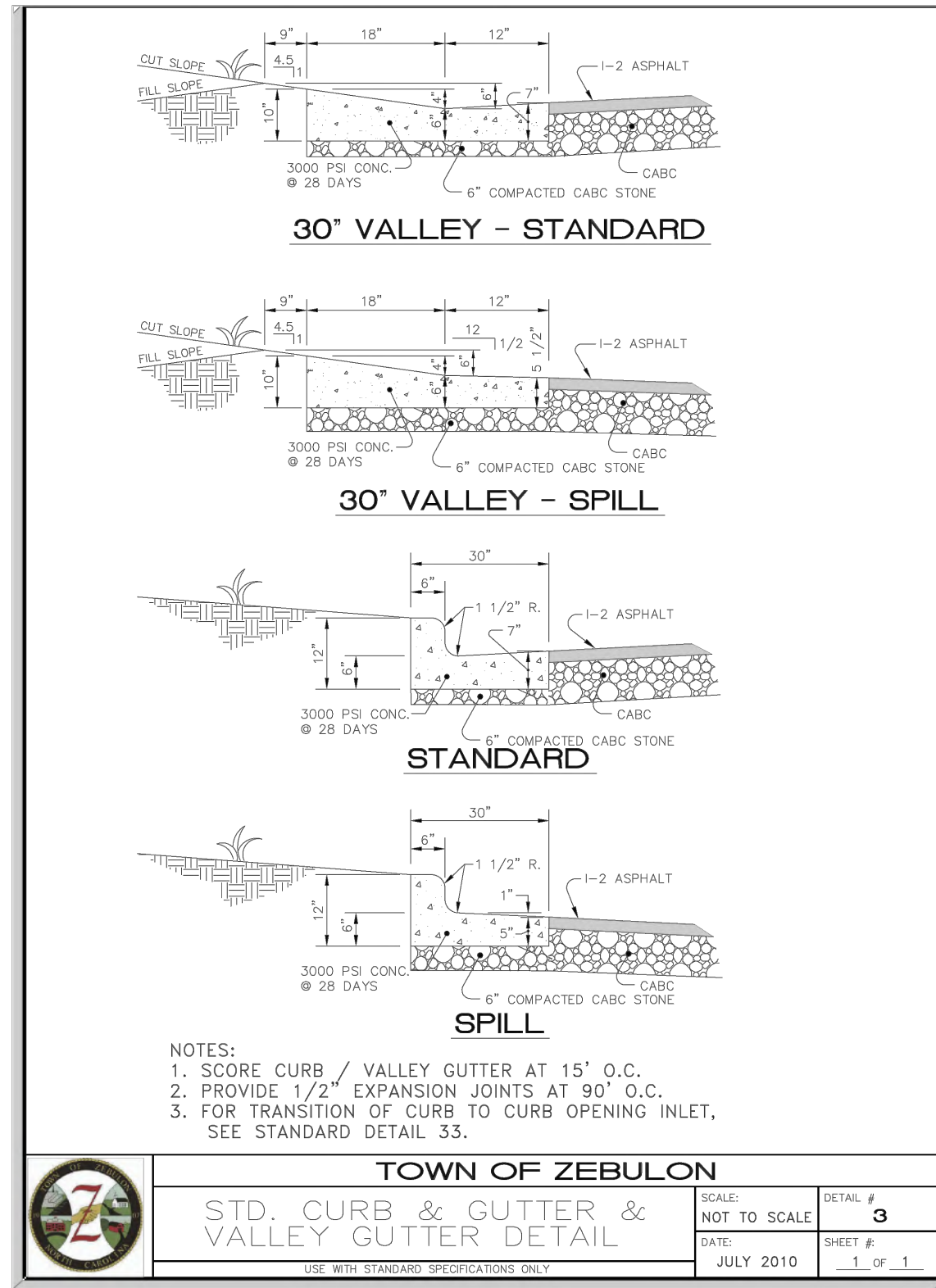
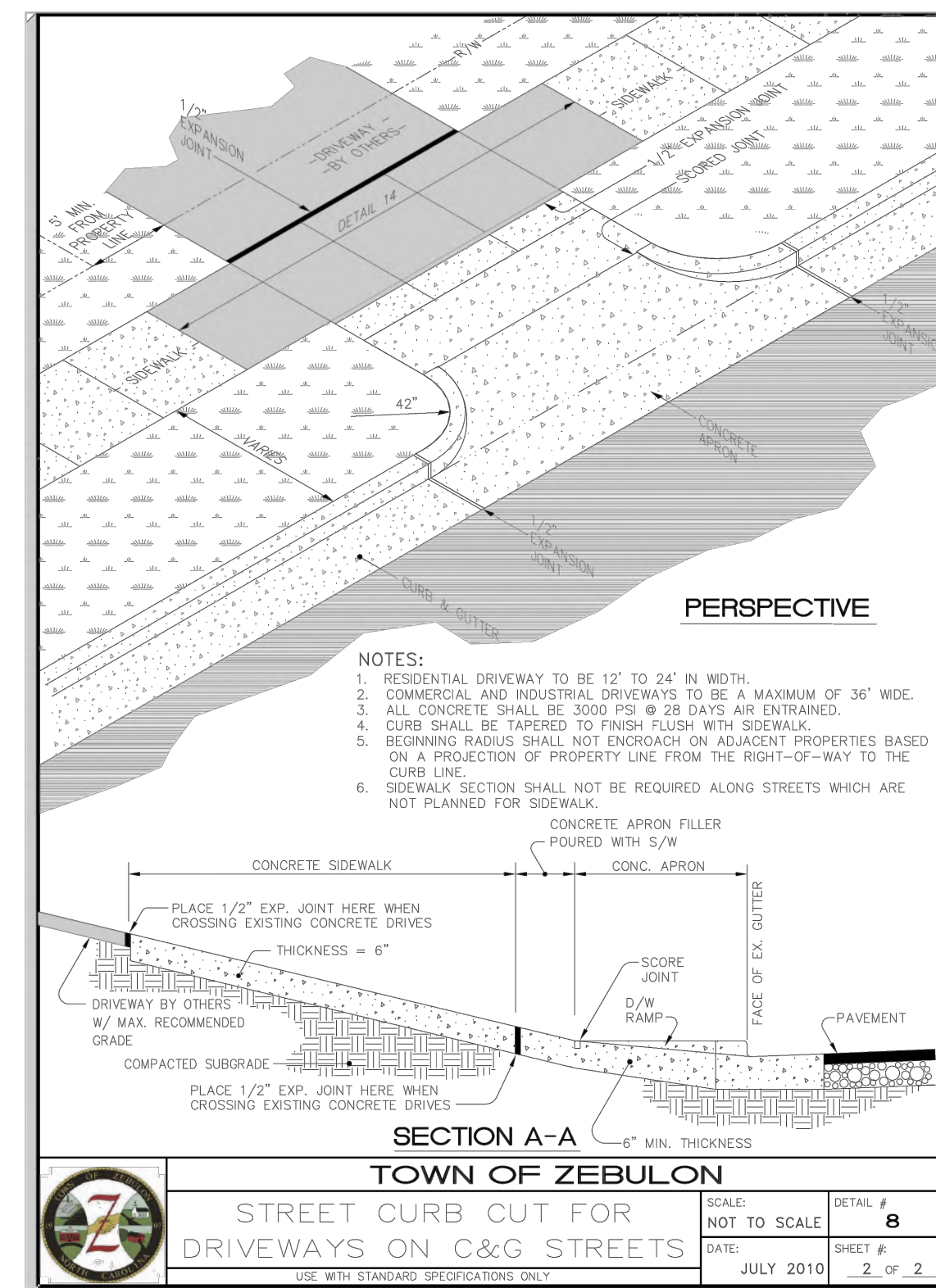
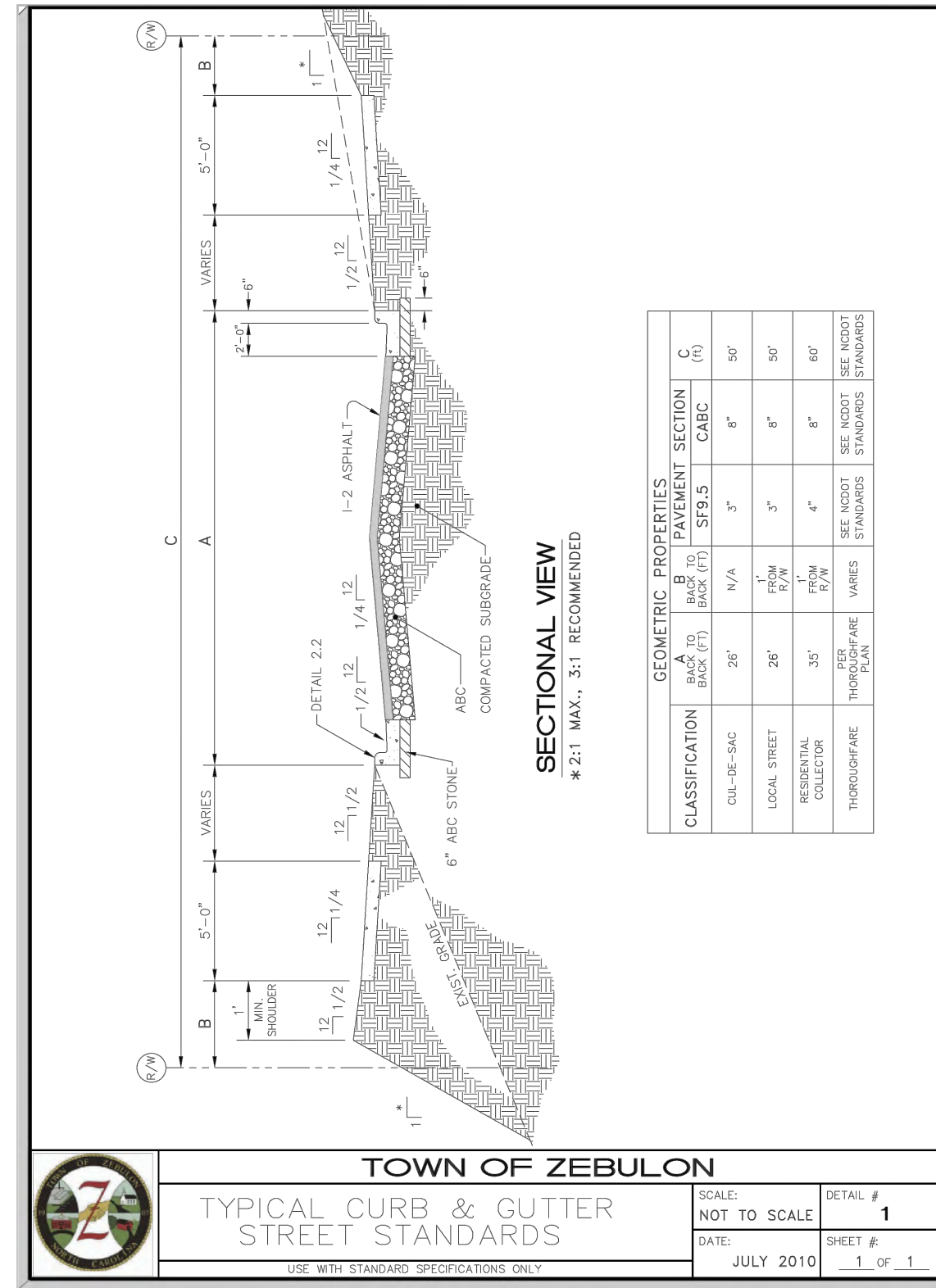

NO ENGINEERING LICENSE NO. P-0803



PRELIMINARY FOR REVIEW ONLY

THE SITE GROUP
 CIVIL ENGINEERS • LANDSCAPE ARCHITECTS
 THE SITE GROUP, P.L.L.C.
 10000 NC-46
 Raleigh, NC 27605-1136 USA
 Office: 919.835.4787
 Fax: 919.839.2255
 E Mail: SRN@thesitegroup.net

CONSTRUCTION DRAWINGS FOR:
BARBEE ST. SUBDIVISION
 0 E. BARBEE STREET
 ZEBULON, NORTH CAROLINA

Drawn By: **WRR**
 Checked By: **SRN**

DATE: 07 NOV 2022

CONSTRUCTION DRAWING

SITE DETAILS

Job Code: **SCBSZ**

Dwg No. **SITE 701**

Copyright © 2022 The Site Group, P.L.L.C. ALL RIGHTS RESERVED

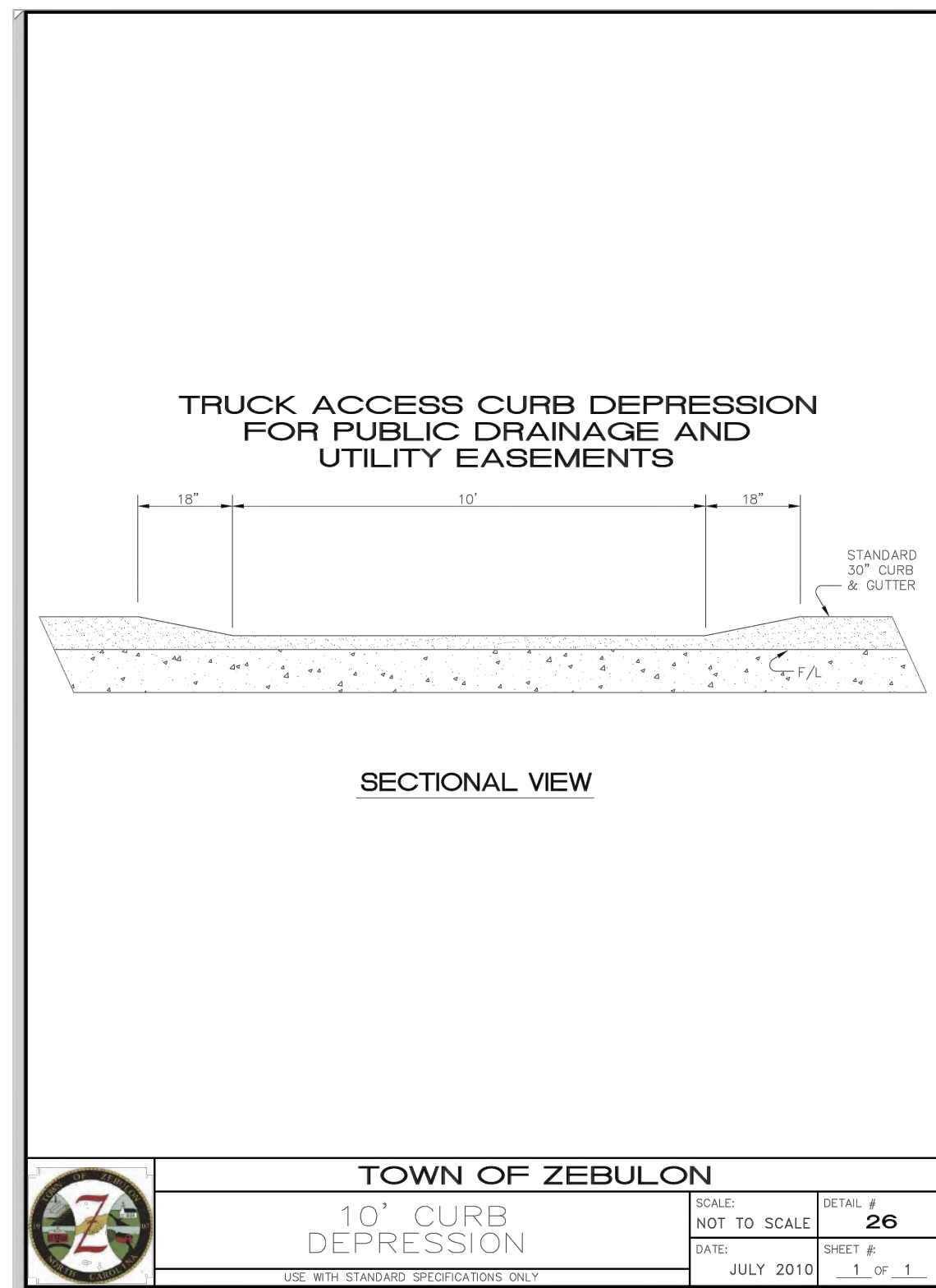
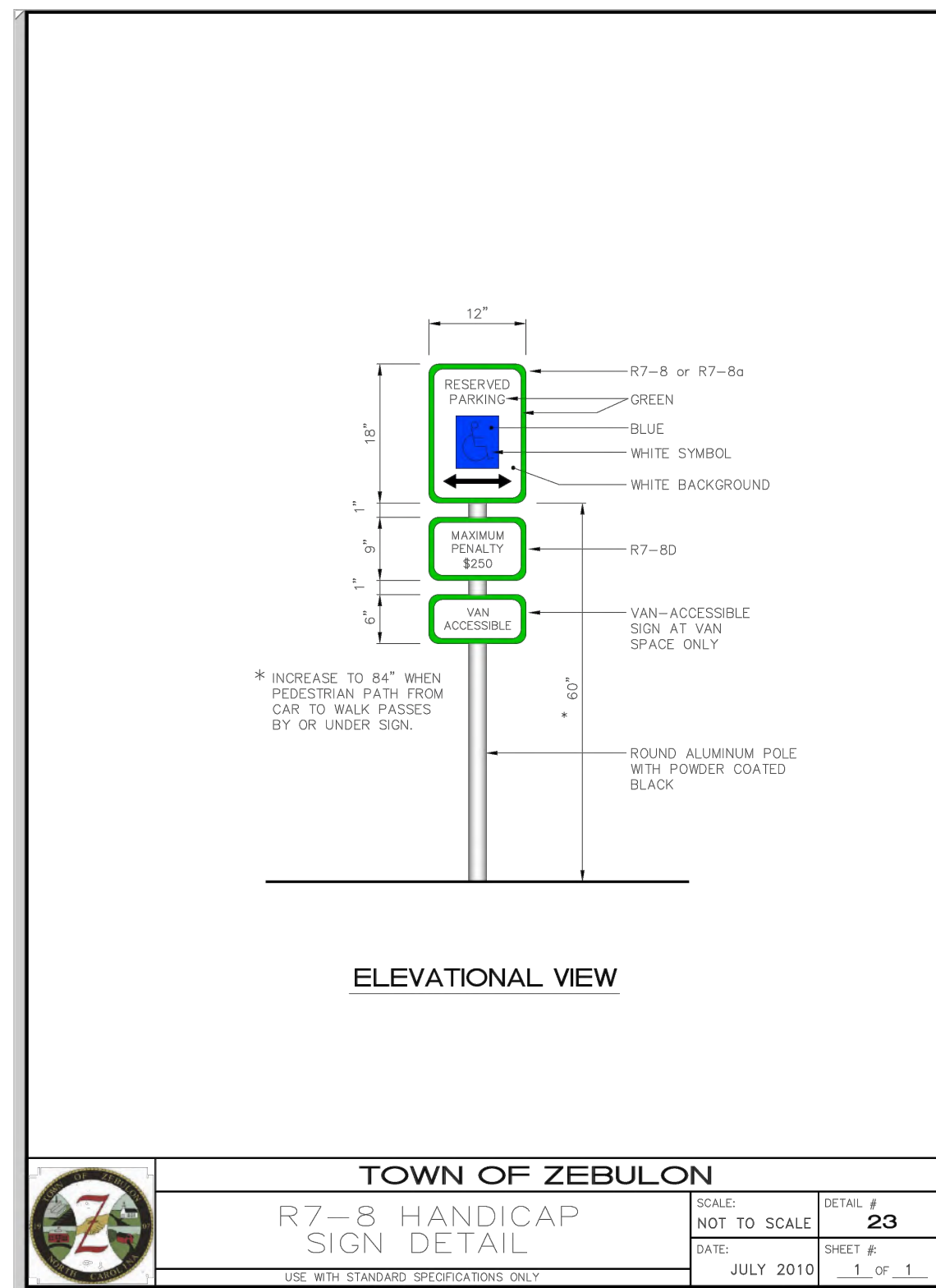
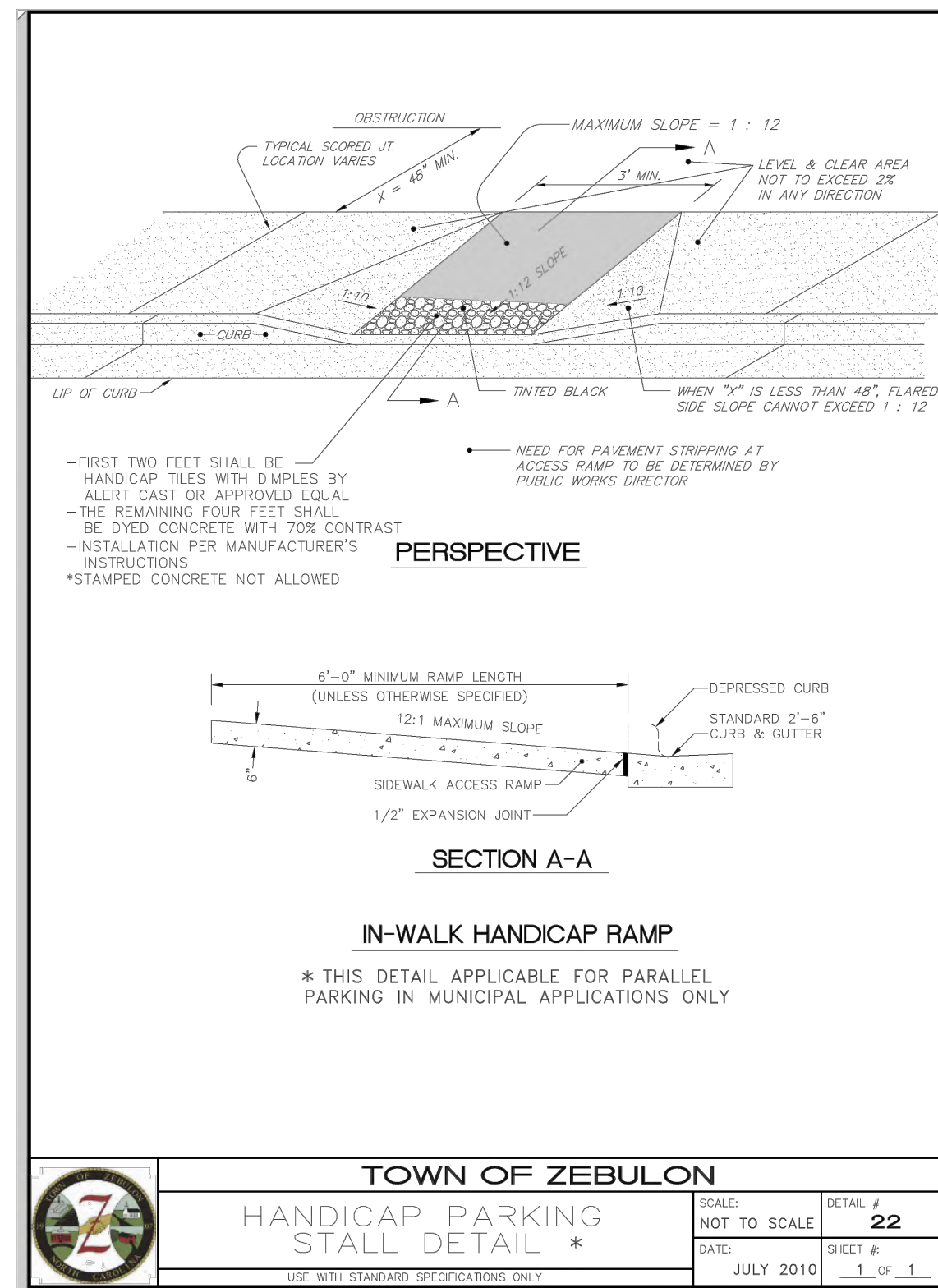
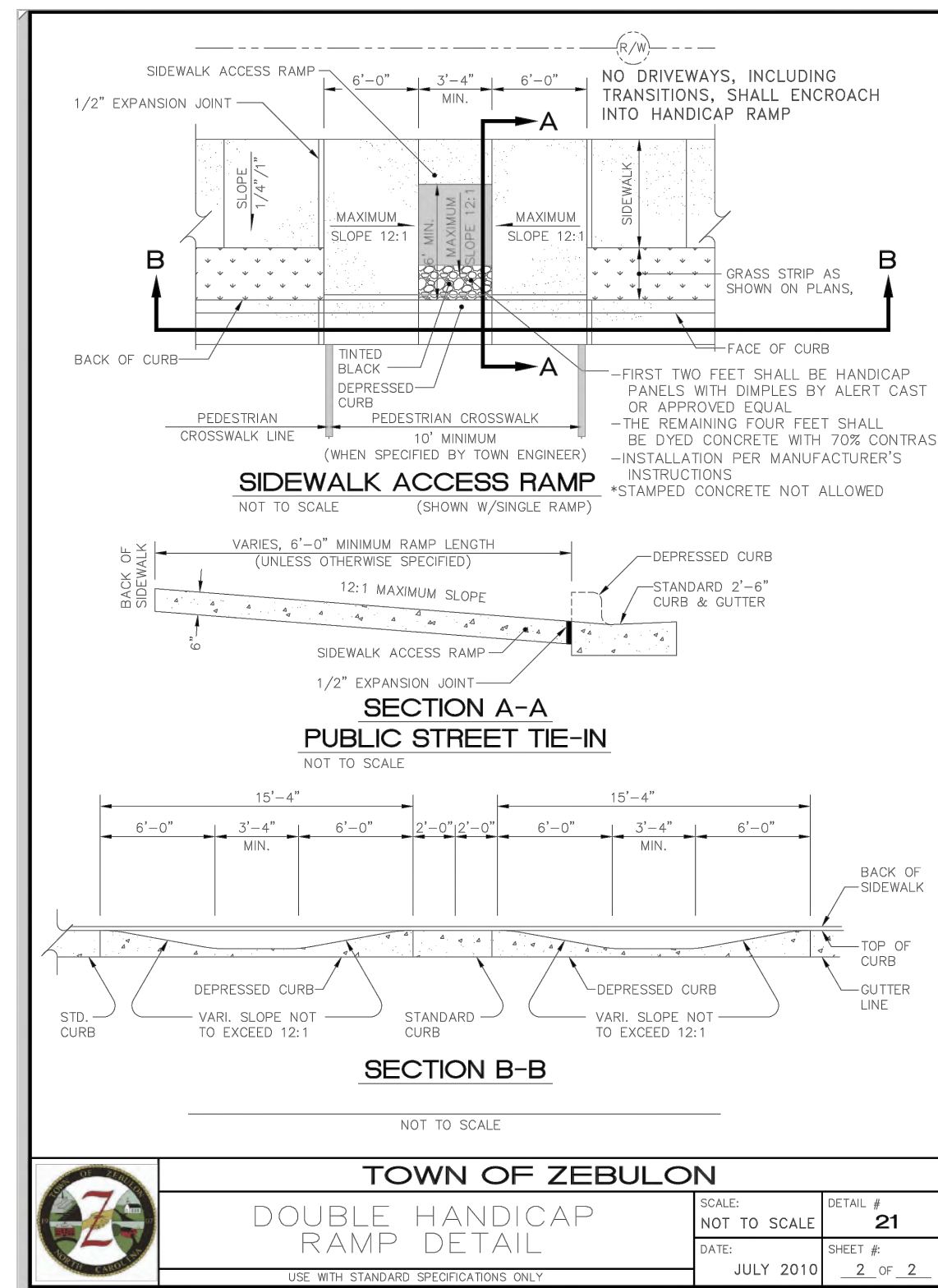
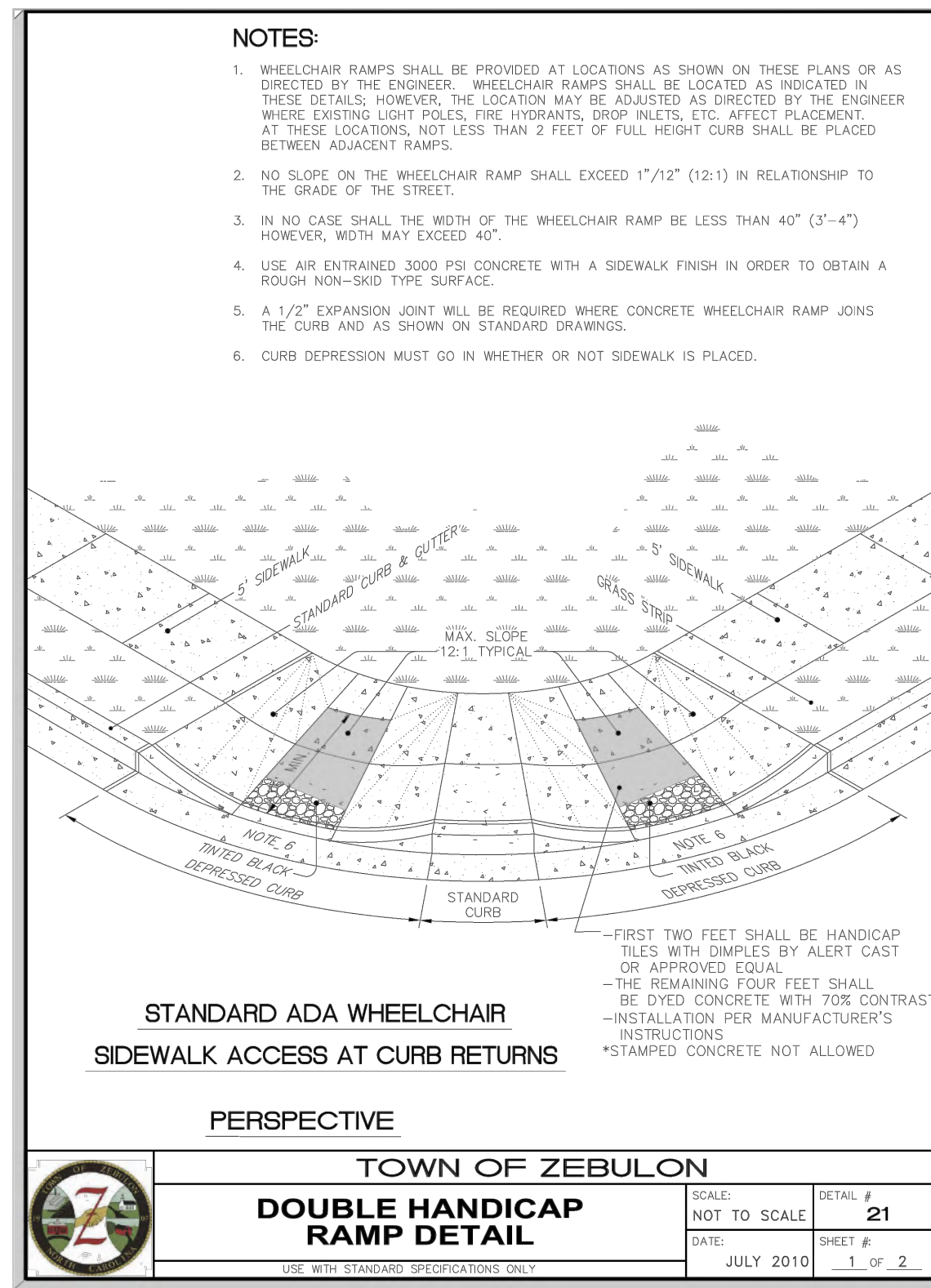
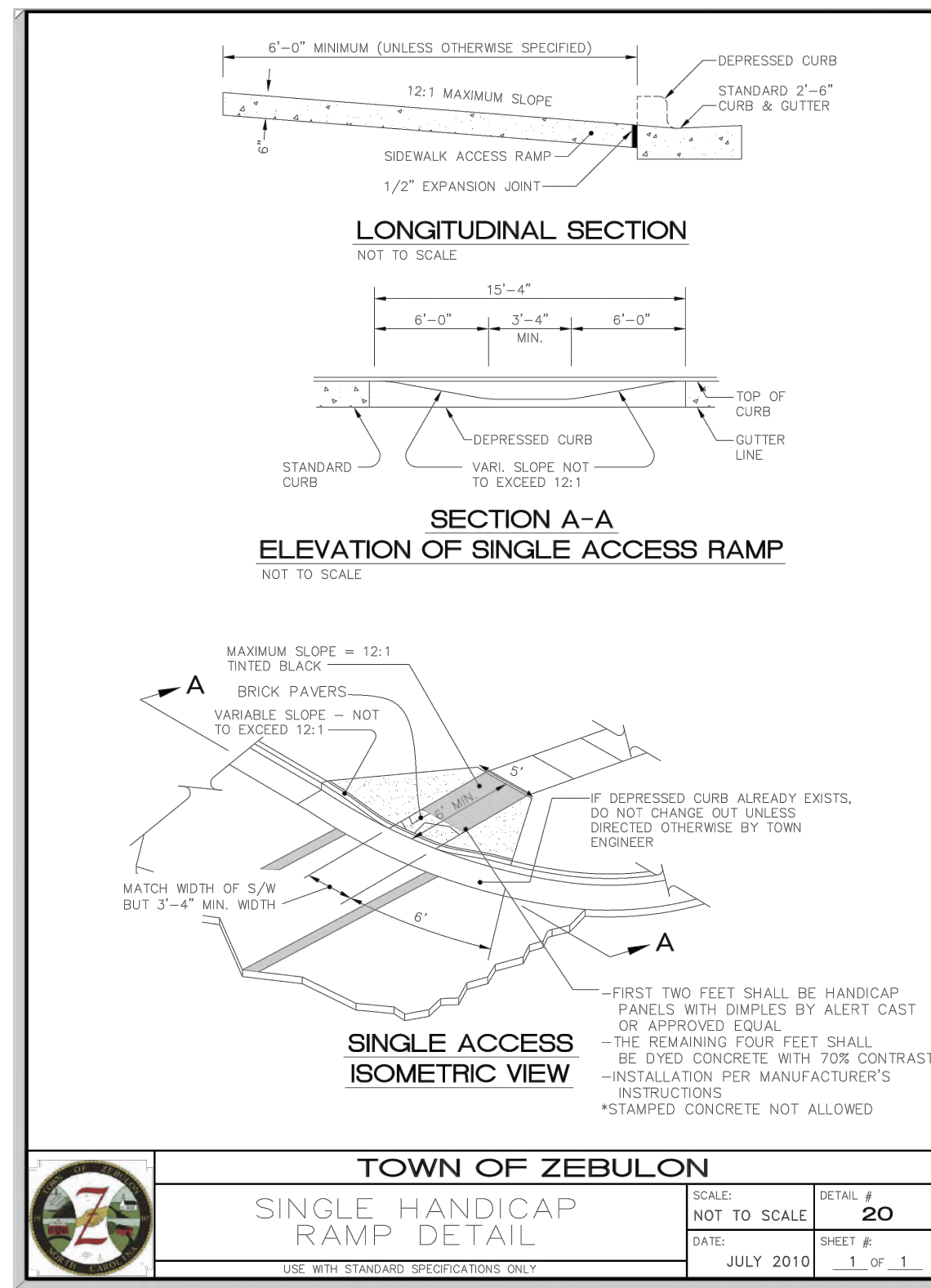
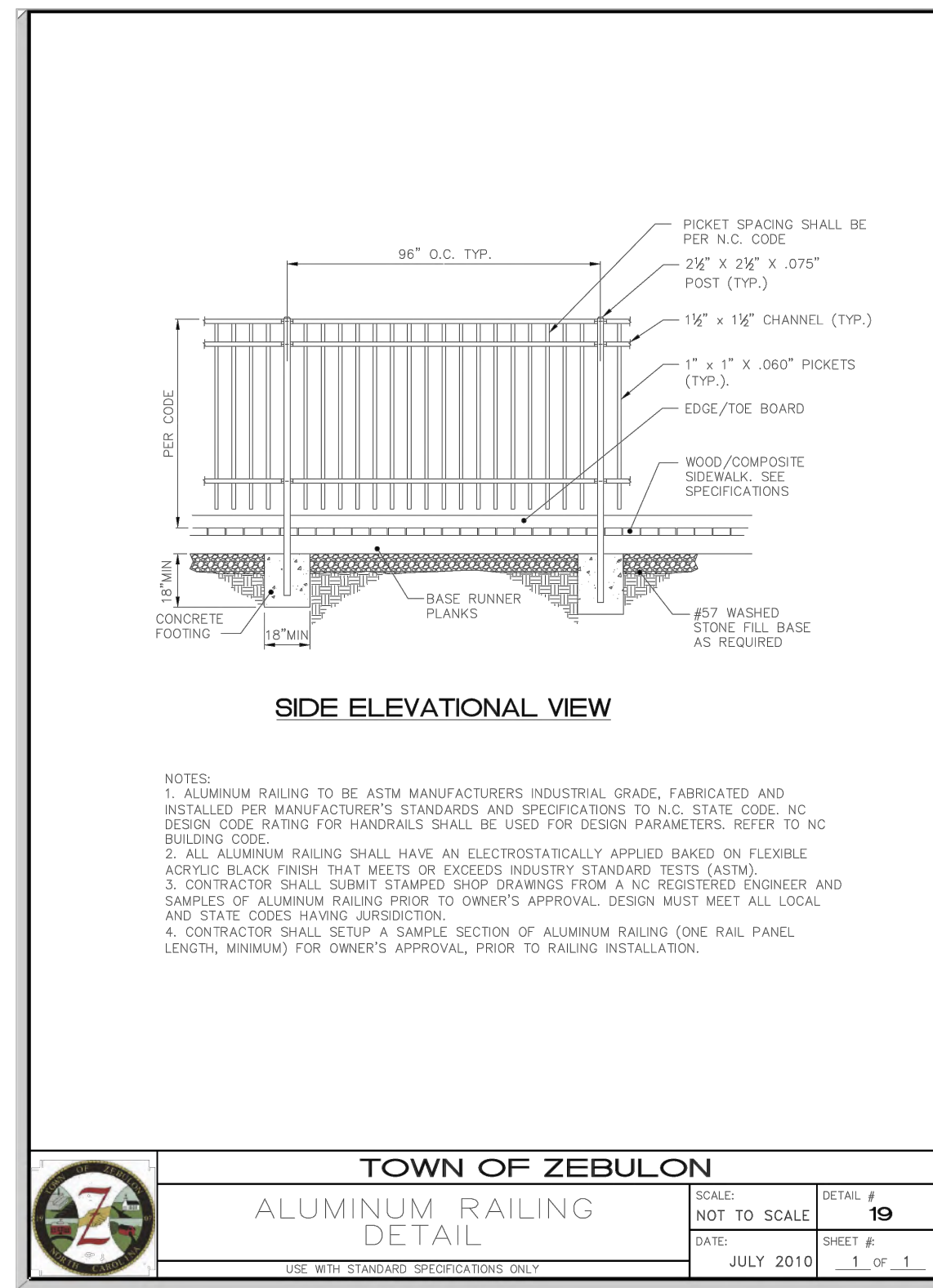
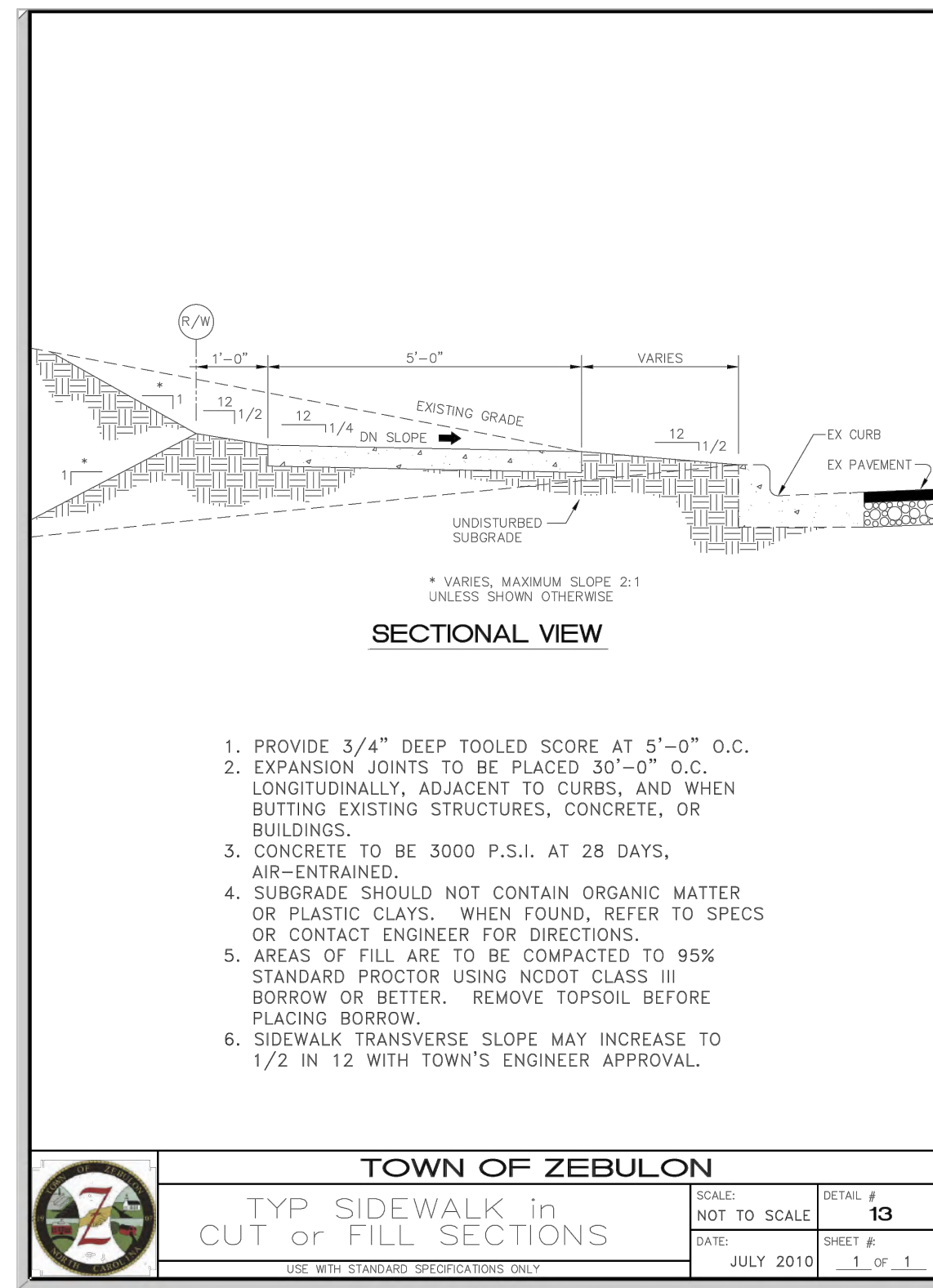

NO ENGINEERING LICENSE NO. P-0803



PRELIMINARY FOR REVIEW ONLY

THE SITE GROUP
 CIVIL ENGINEERS • LANDSCAPE ARCHITECTS
 THE SITE GROUP, PLLC
 1000 N. W. 27th St., Suite 1136
 Raleigh, NC 27605-4787
 Office: 919.835.4787
 Fax: 919.839.2255
 E-Mail: SRN@thesitegroup.net

CONSTRUCTION DRAWINGS FOR:
BARBEE ST. SUBDIVISION
 0 E. BARBEE STREET
 ZEBULON, NORTH CAROLINA

Drawn By: **WRR**
 Checked By: **SRN**

DATE: 07 NOV 2022

CONSTRUCTION DRAWING

SITE DETAILS

Job Code: **SCBSZ**

Dwg No. **SITE 702**

Copyright © 2022 The Site Group, PLLC. ALL RIGHTS RESERVED.

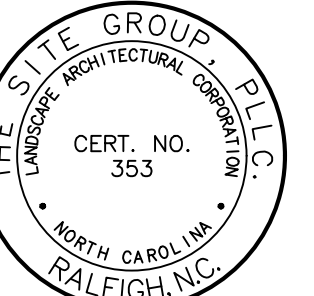
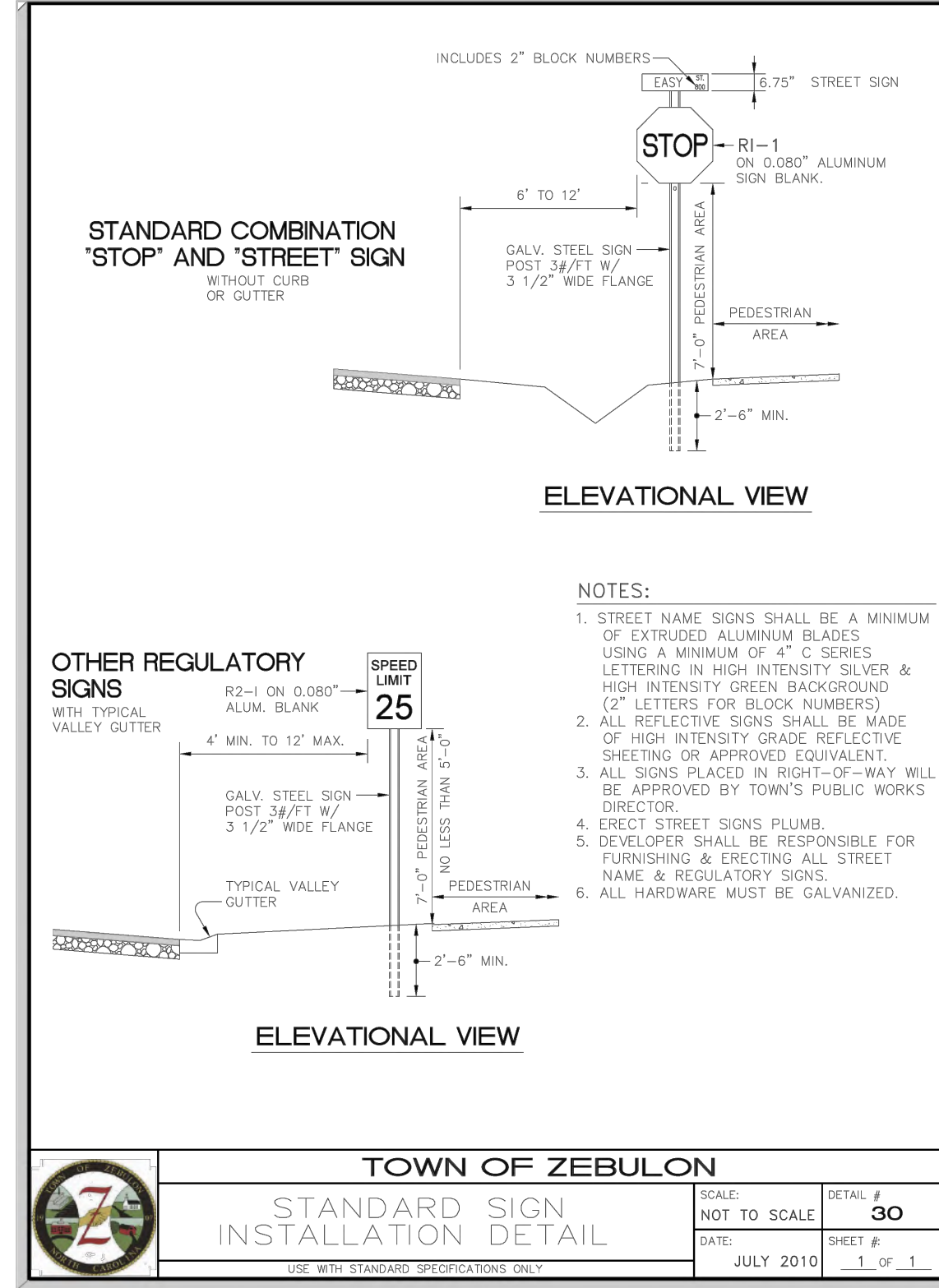
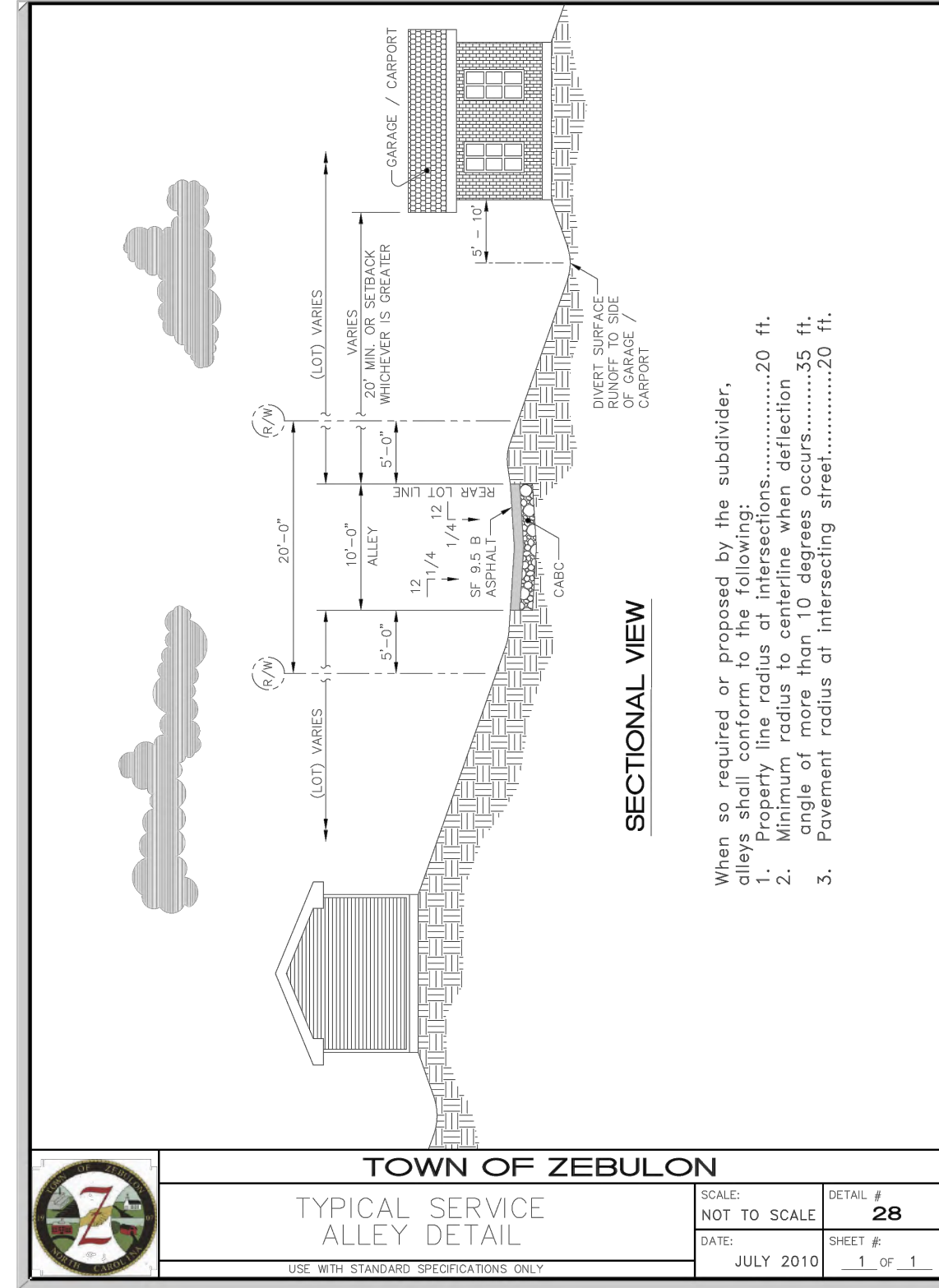

NC ENGINEERING LICENSE NO. P-0803



PRELIMINARY FOR REVIEW ONLY

THE SITE GROUP
CIVIL ENGINEERS • LANDSCAPE ARCHITECTS

THE SITE GROUP, PLLC
10000 Old 27609-1136 USA
Raleigh, NC 27609-1136
Office: 919.835.4787
Fax: 919.839.2255
E Mail: SRN@thesitegroup.net

CONSTRUCTION DRAWINGS FOR:
BARBEE ST. SUBDIVISION
0 E. BARBEE STREET
ZEBULON, NORTH CAROLINA

Drawn By: **WRR**
Checked By: **SRN**

DATE: 07 NOV 2022

CONSTRUCTION DRAWING

SITE DETAILS

Job Code: **SCBSZ**

Dwg No. **SITE 703**

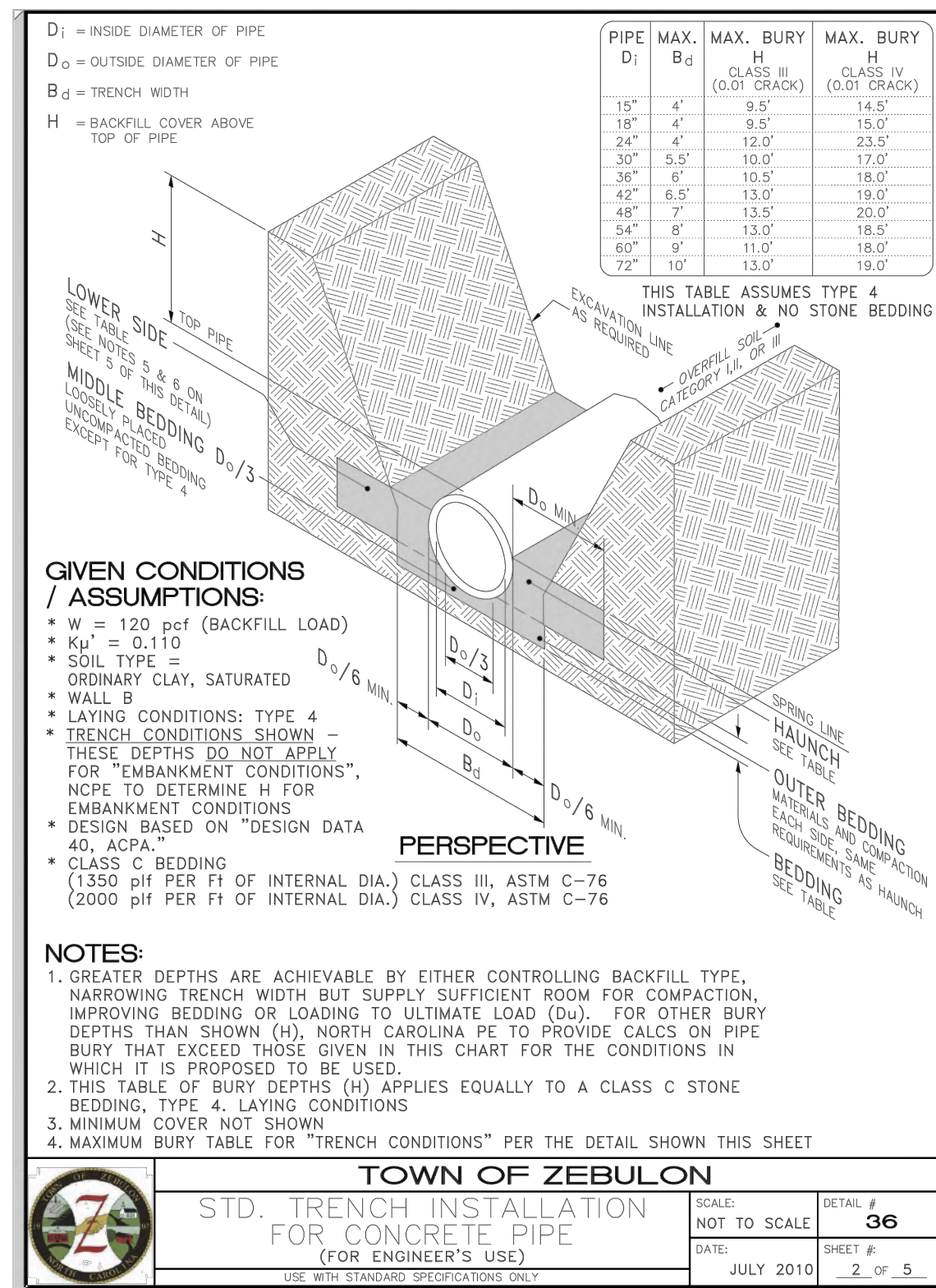
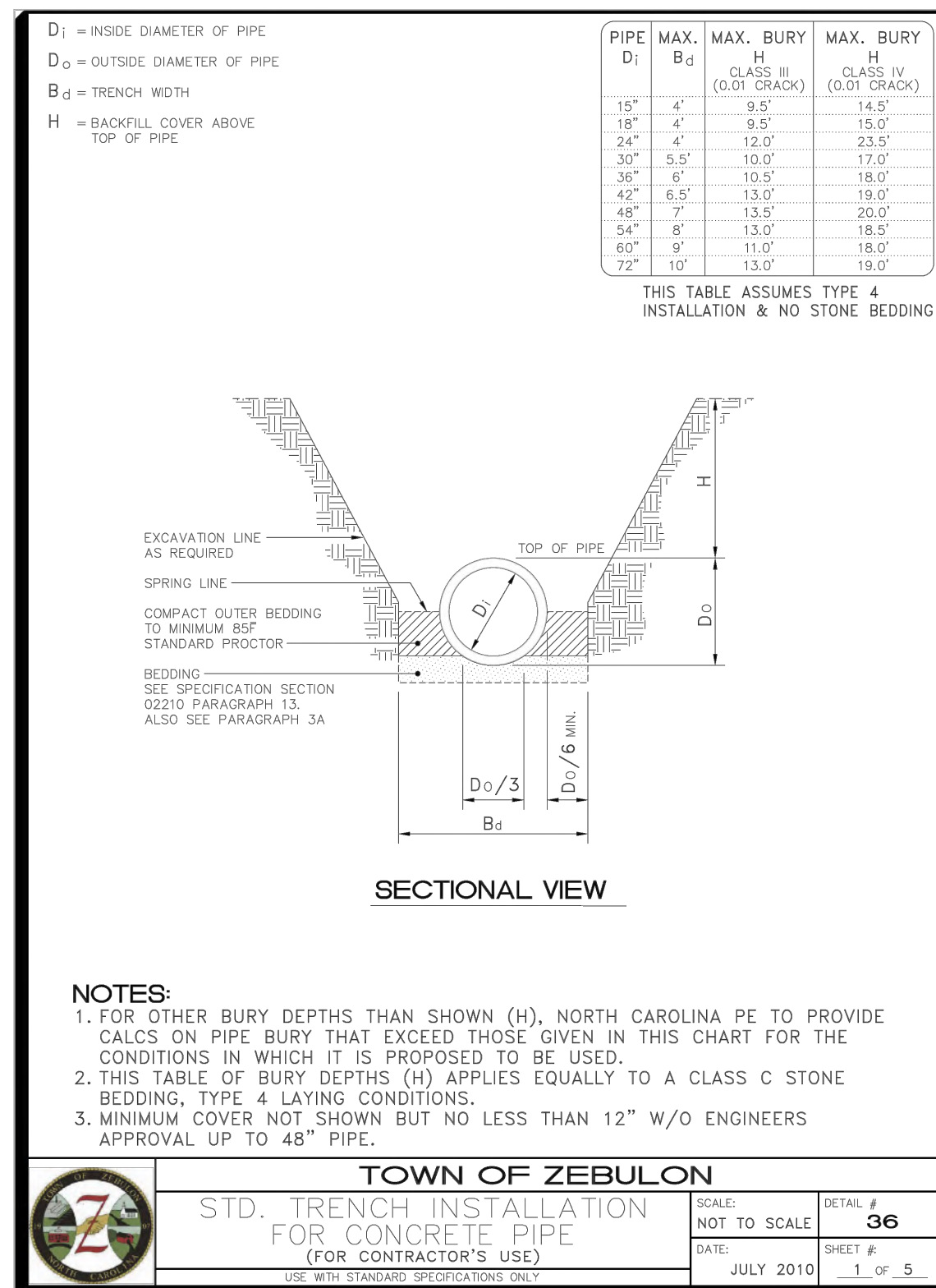
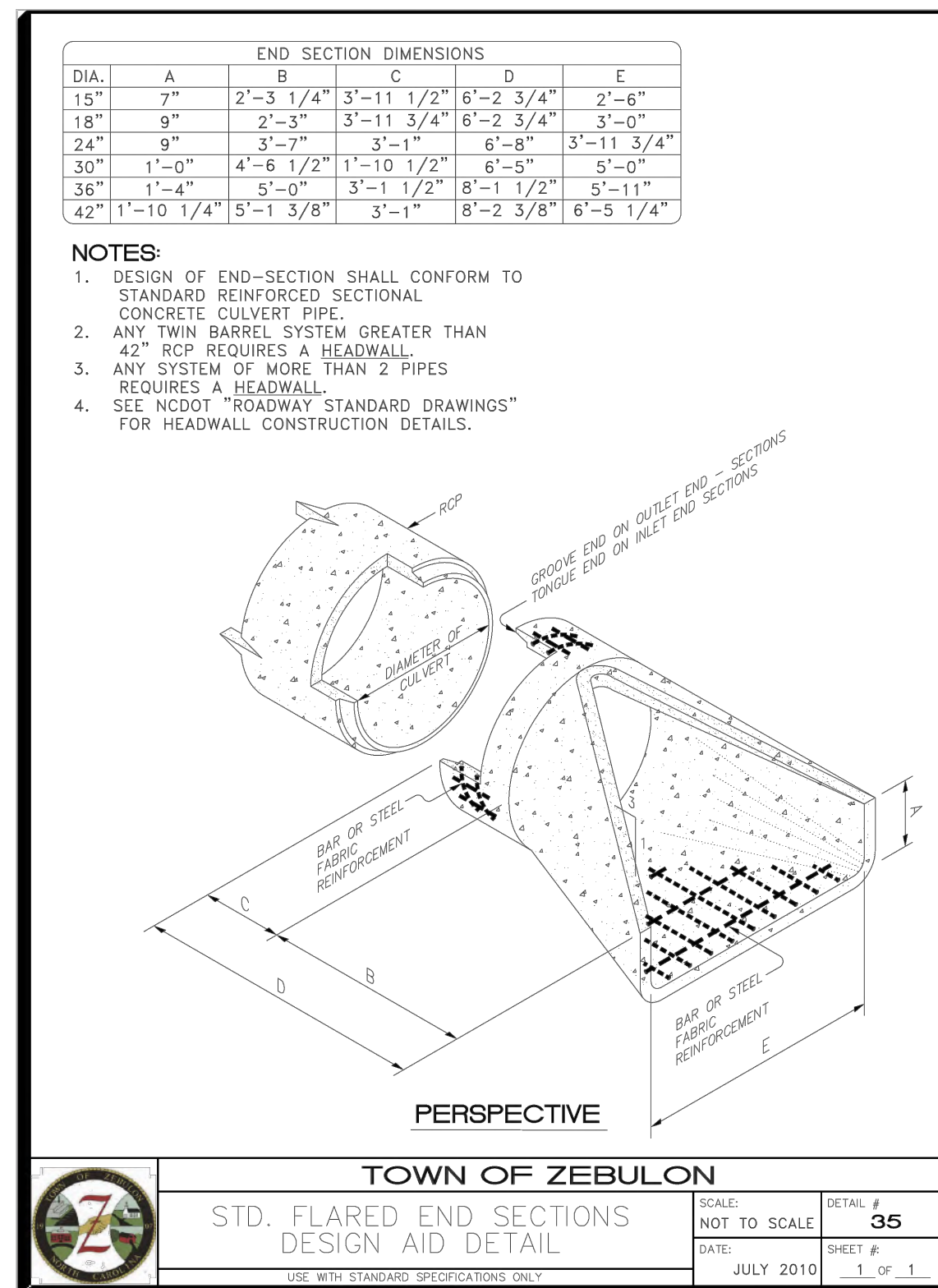
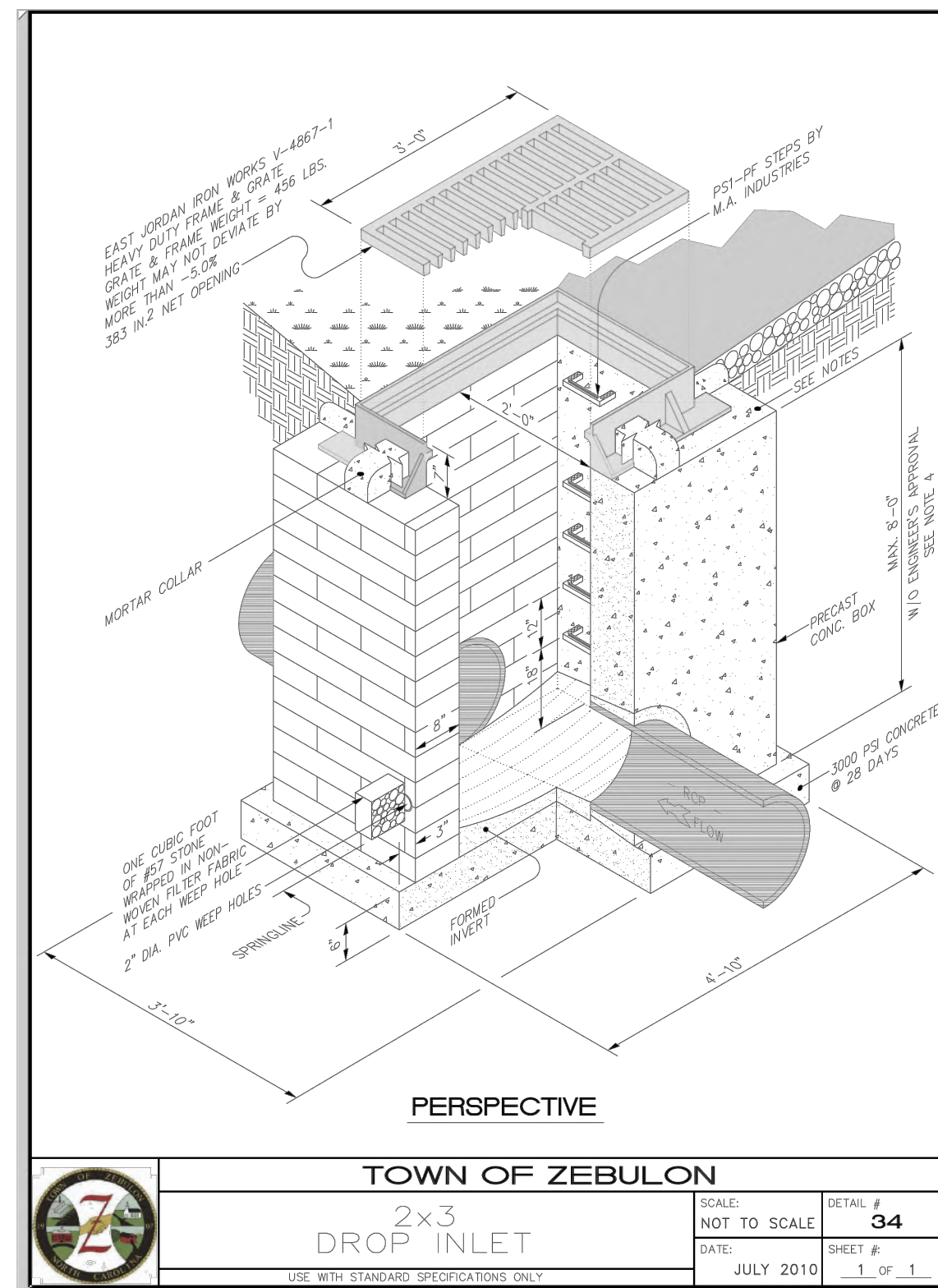
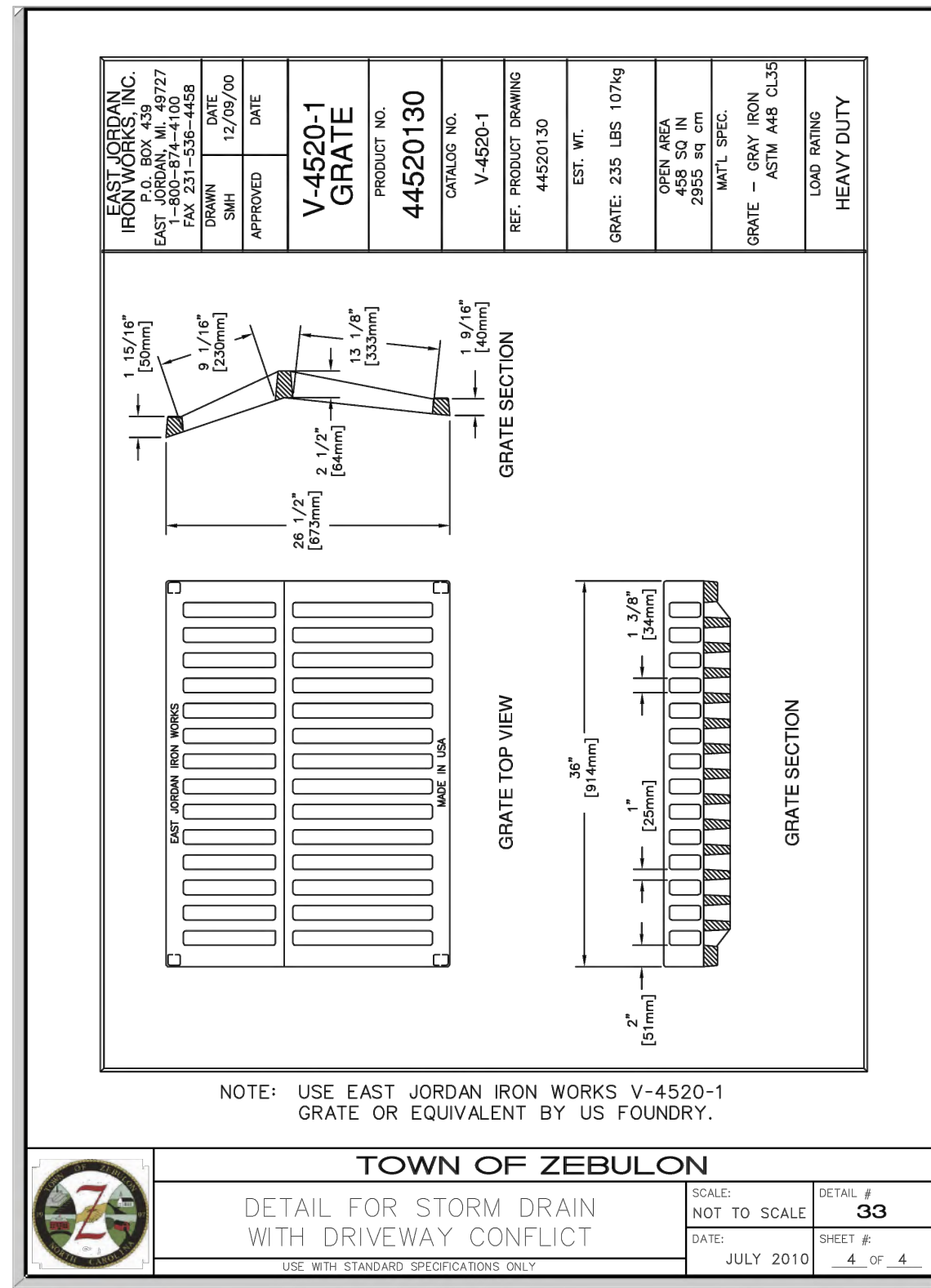
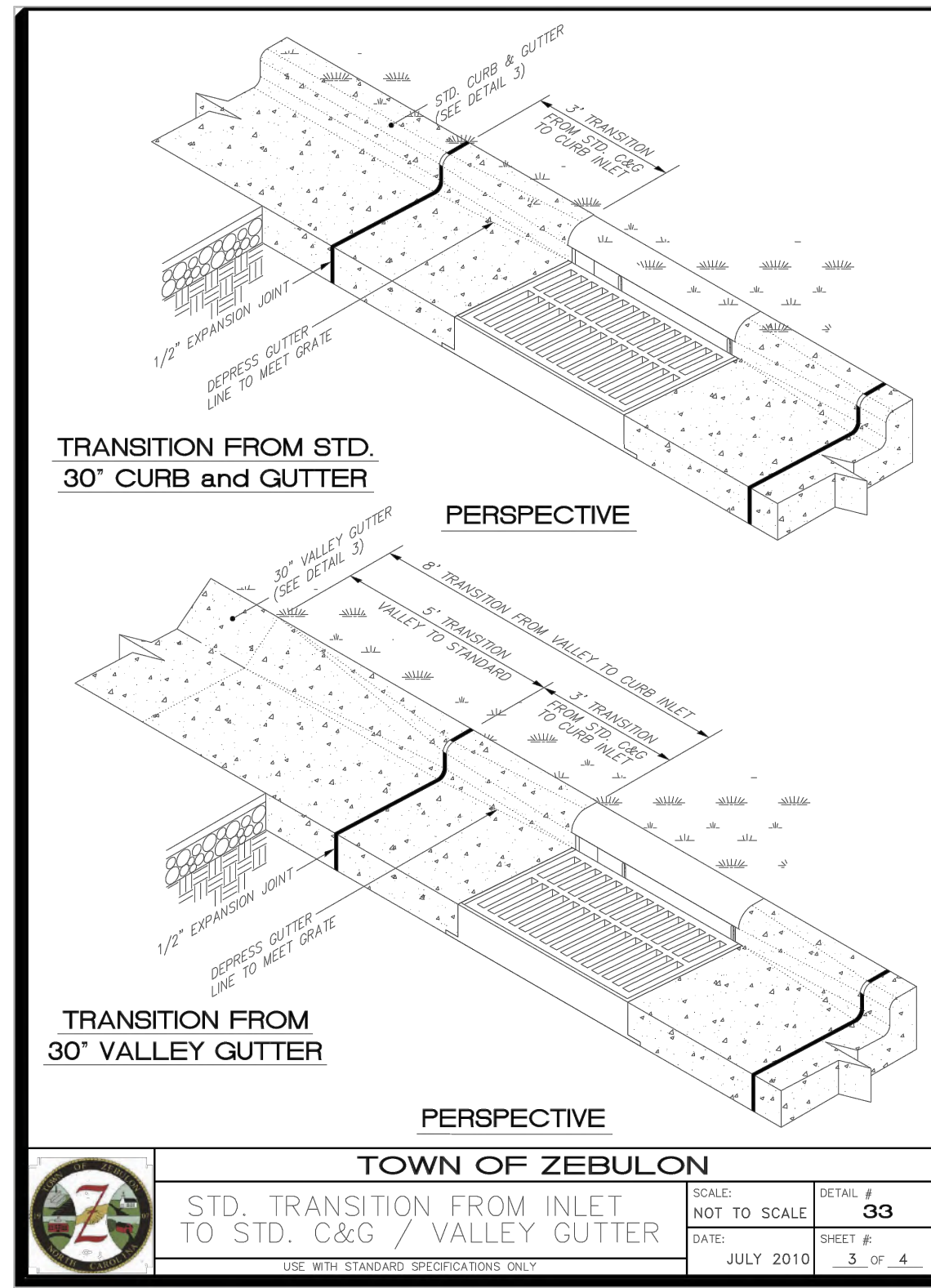
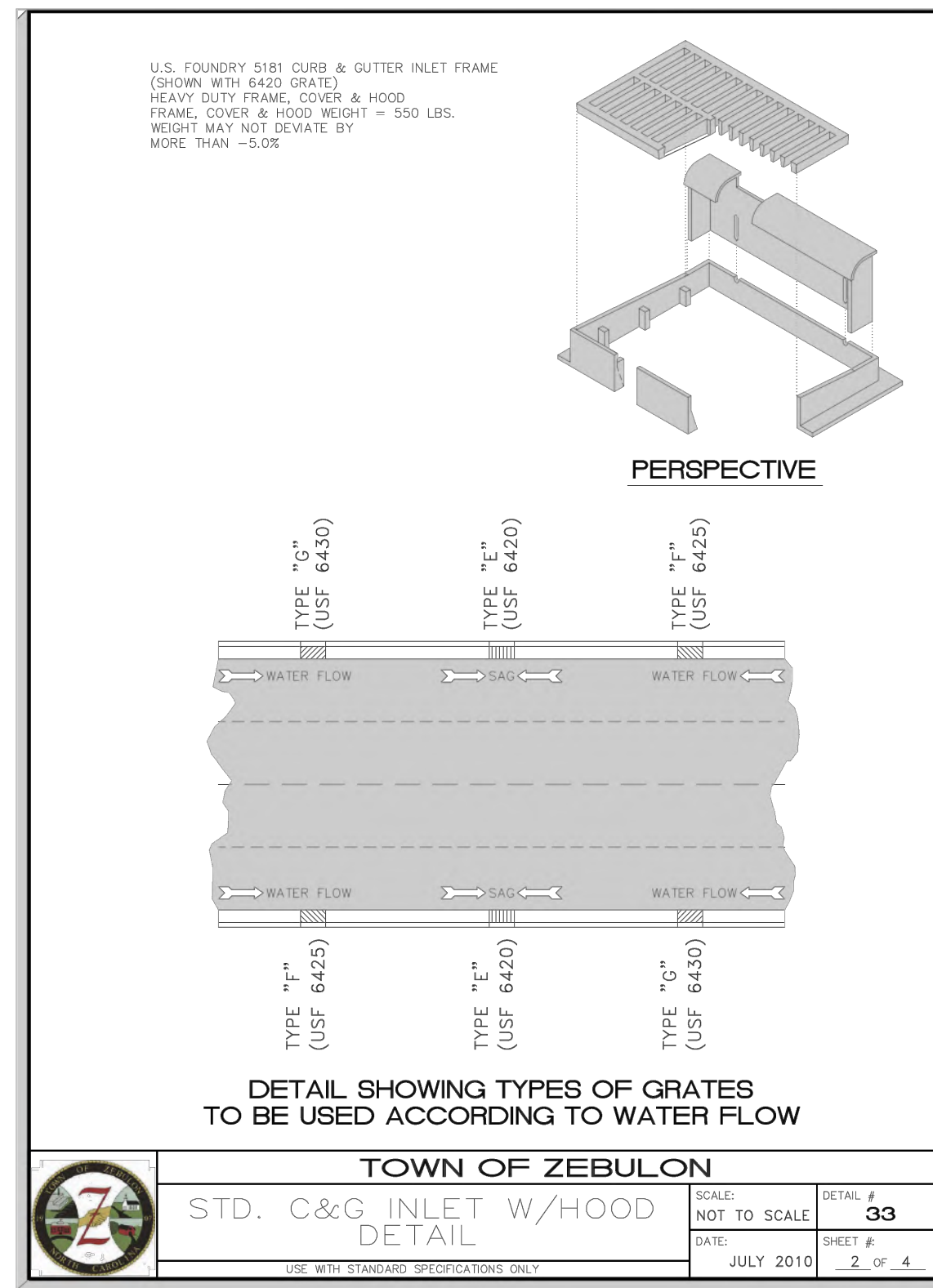
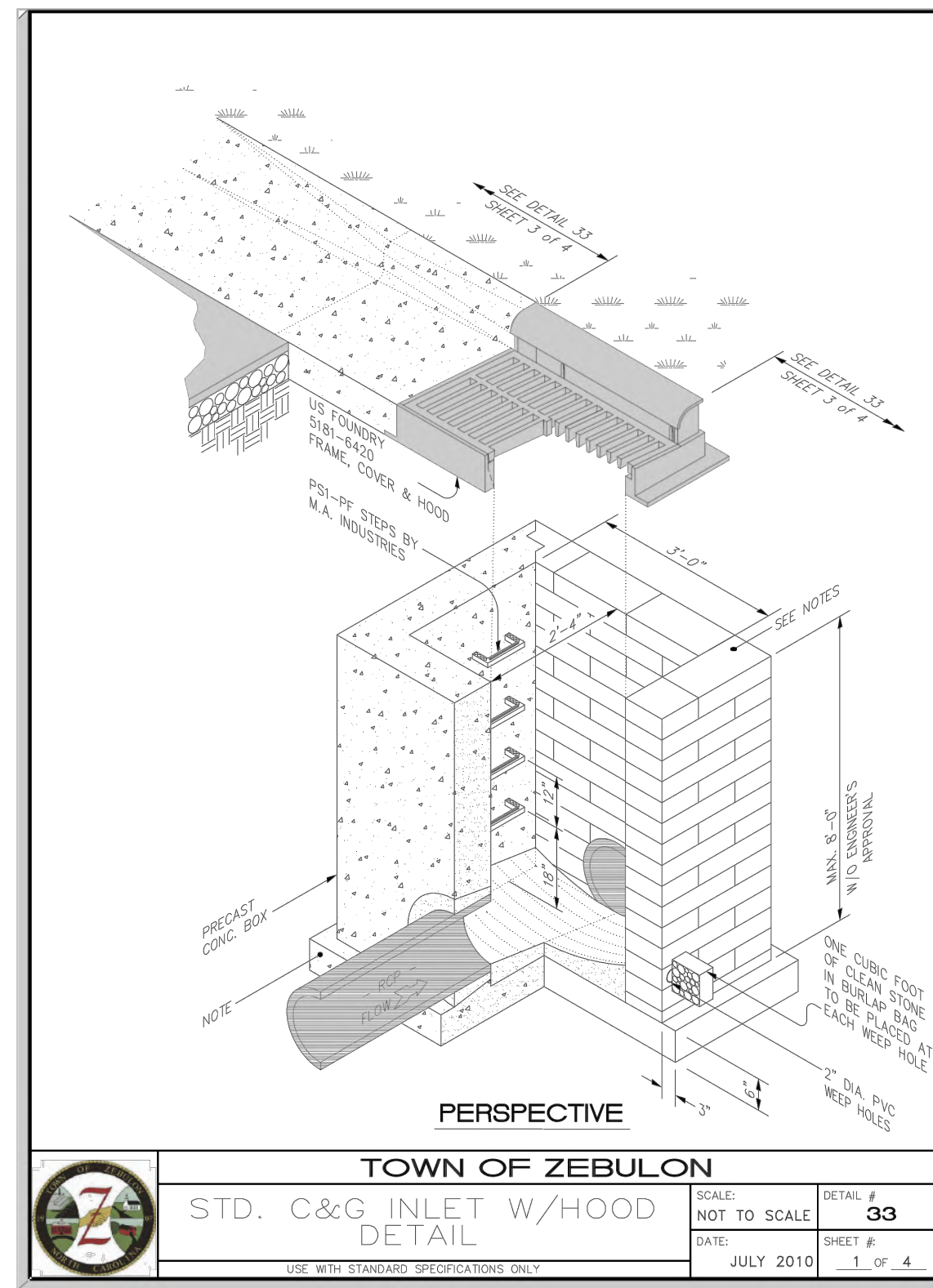

NC ENGINEERING
 LICENSE NO. P-0803



PRELIMINARY FOR
 REVIEW ONLY

THE SITE GROUP
 CIVIL ENGINEERS • LANDSCAPE ARCHITECTS
 THE SITE GROUP, PLLC.
 1000 S. GARDEN ST., SUITE 200
 RALEIGH, NC 27605-1136 USA
 Office: 919.835.4787
 Fax: 919.839.2255
 E Mail: SRN@thesitegroup.net

CONSTRUCTION DRAWINGS FOR:
BARBEE ST. SUBDIVISION
 0 E. BARBEE STREET
 ZEBULON, NORTH CAROLINA

Drawn By: **WRR**
 Checked By: **SRN**

DATE:
 07 NOV 2022

CONSTRUCTION
 DRAWING

SITE
 DETAILS

Job Code: **SCBSZ**

Dwg No.
SITE
704

Copyright © 2022 The Site Group, PLLC. ALL RIGHTS RESERVED.

Table 1 Equivalent USCS and AASHTO Soil Classification for SIDD Soil Designations					
SIDD Soil	Representative Soil Types		Percent Compaction		Modified Proctor
	USCS	AASHTO	Standard Proctor	Modified Proctor	
Gravelly Sand (Category I)	SW, SP, GW, GP	A1,A3	100	95	90
			90	85	80
			80	75	70
Sandy Silt (Category II)	OM, SM, ML, Also GC, SC with less than 20% passing #200 sieve	A2,A4	100	95	90
			90	85	80
			85	80	75
			80	75	70
Silty Clay (Category III)	CL, MH, GC, SC	A5,A6	100	90	85
			90	80	75
			85	75	70
			80	70	65
OH			100	90	85
			90	80	75

Table 2 Standard EMBANKMENT Installation Soils and Minimum Compaction Requirements			
Installation Type ¹	Bedding Thickness	Haunch and Outer Bedding	Lower Side
Type 1	D ₁₅ /24 minimum, not less than 75 mm (3"). If rock foundation, use D ₁₅ /12 minimum, not less than 150 mm (6").	98% Category I	90% Category I, 95% Category II, or 100% Category III
Type 2	D ₁₅ /24 minimum, not less than 75 mm (3"). If rock foundation, use D ₁₅ /12 minimum, not less than 150 mm (6").	90% Category I or 95% Category II	85% Category I, 90% Category II, or 95% Category III
Type 3	D ₁₅ /24 minimum, not less than 75 mm (3"). If rock foundation, use D ₁₅ /12 minimum, not less than 150 mm (6").	80% Category I, 90% Category II, or 95% Category III	80% Category I, 90% Category II, or 95% Category III
Type 4	D ₁₅ /24 minimum, not less than 75 mm (3"). If rock foundation, use D ₁₅ /12 minimum, not less than 150 mm (6").	No compaction required, except if Category III, use 85% Category III	No compaction required, except if Category III, use 85% Category III

Table 3 Standard TRENCH Installations Soils and Minimum Compaction Requirements			
Installation Type ¹	Bedding Thickness	Haunch Outer Bedding	Lower Side
Type 1	D ₁₅ /24 minimum, not less than 75 mm (3"). If rock foundation, use D ₁₅ /12 minimum, not less than 150 mm (6").	98% Category I	90% Category I, 95% Category II, or 100% Category III
Type 2	D ₁₅ /24 minimum, not less than 75 mm (3"). If rock foundation, use D ₁₅ /12 minimum, not less than 150 mm (6").	90% Category I or 95% Category II	85% Category I, 90% Category II, or 95% Category III
Type 3	D ₁₅ /24 minimum, not less than 75 mm (3"). If rock foundation, use D ₁₅ /12 minimum, not less than 150 mm (6").	80% Category I, 90% Category II, or 95% Category III	80% Category I, 90% Category II, or 95% Category III
Type 4	D ₁₅ /24 minimum, not less than 75 mm (3"). If rock foundation, use D ₁₅ /12 minimum, not less than 150 mm (6").	No compaction required, except if Category III, use 85% Category III	No compaction required, except if Category III, use 85% Category III

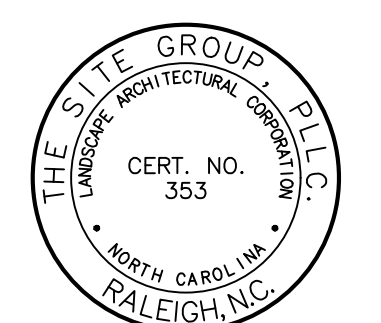
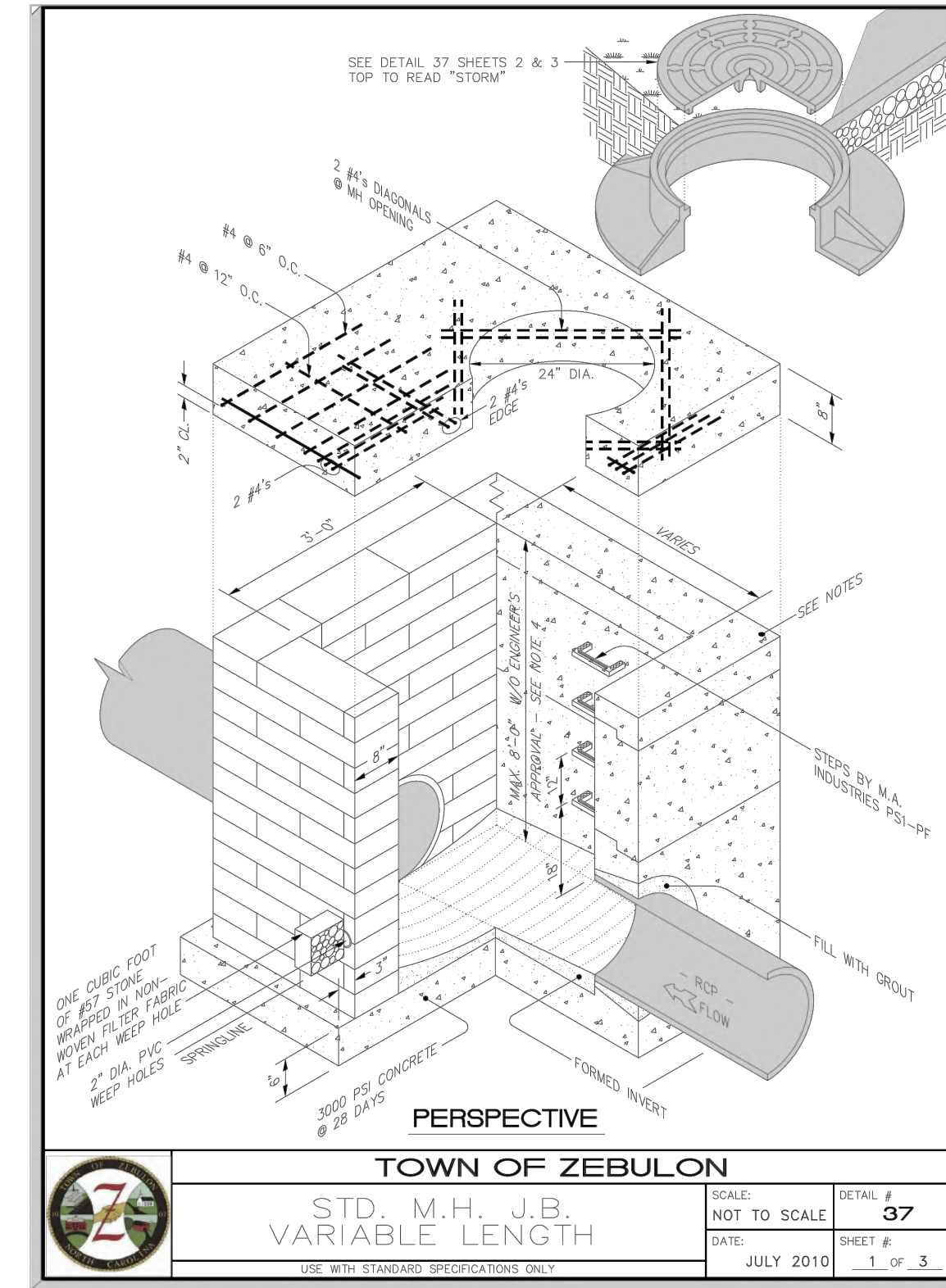

PRELIMINARY FOR REVIEW ONLY

THE SITE GROUP
 CIVIL ENGINEERS • LANDSCAPE ARCHITECTS
 THE SITE GROUP, PLLC.
 1000 N. W. 27th St., Suite 1136
 Raleigh, NC 27605-4787
 Office: 919.835.4787
 Fax: 919.839.2255
 E-Mail: SRN@thesitegroup.net

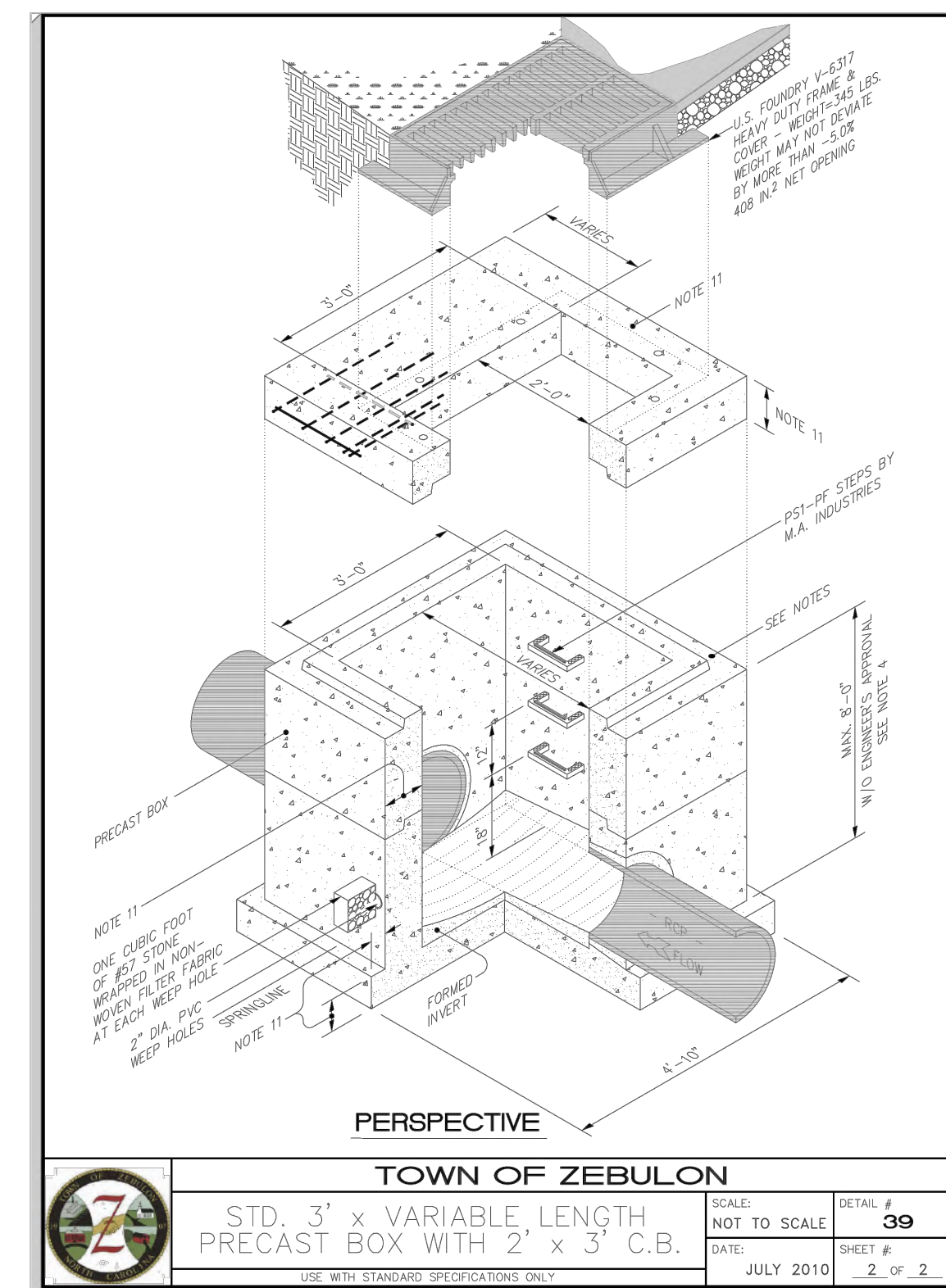
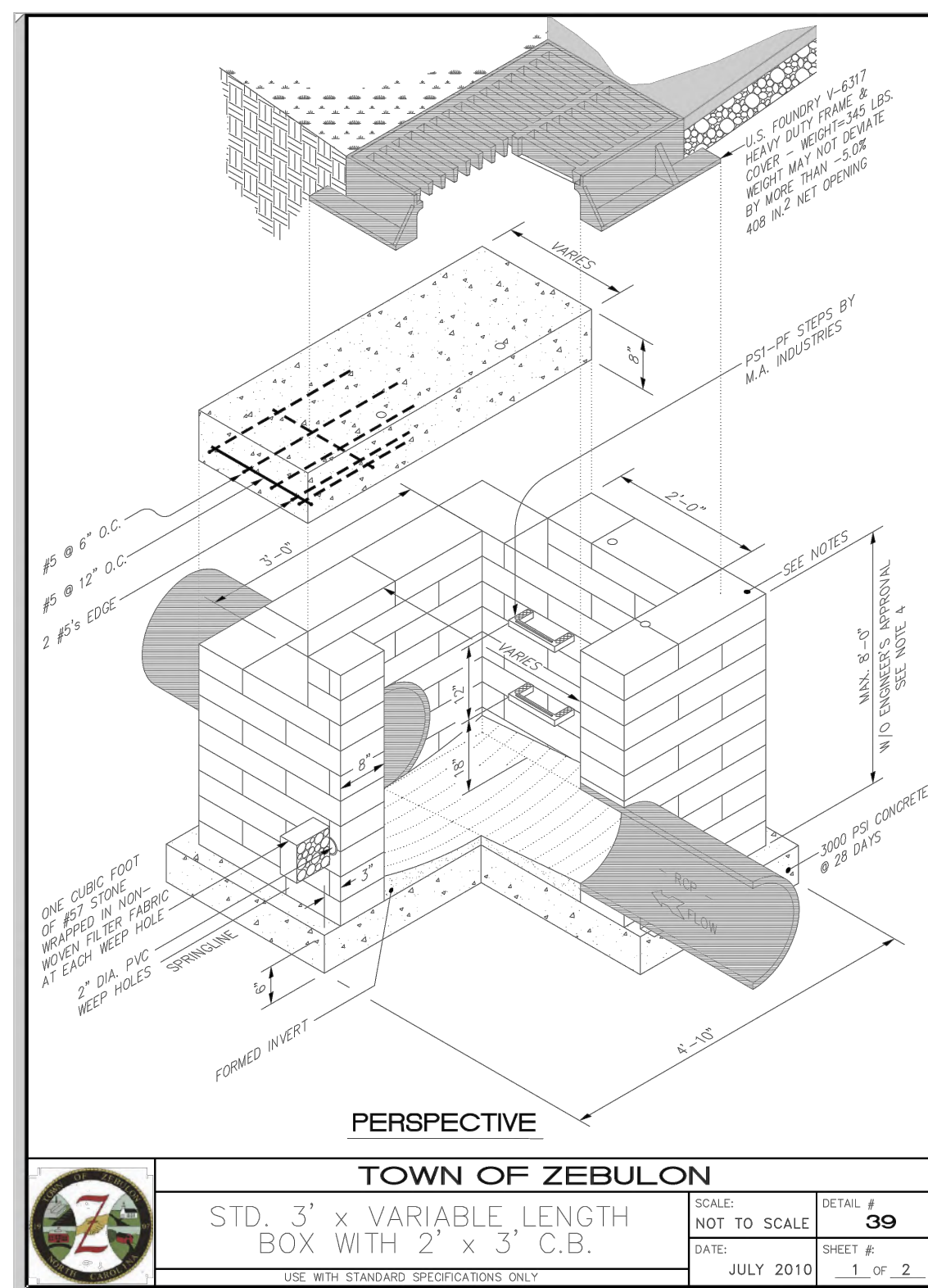
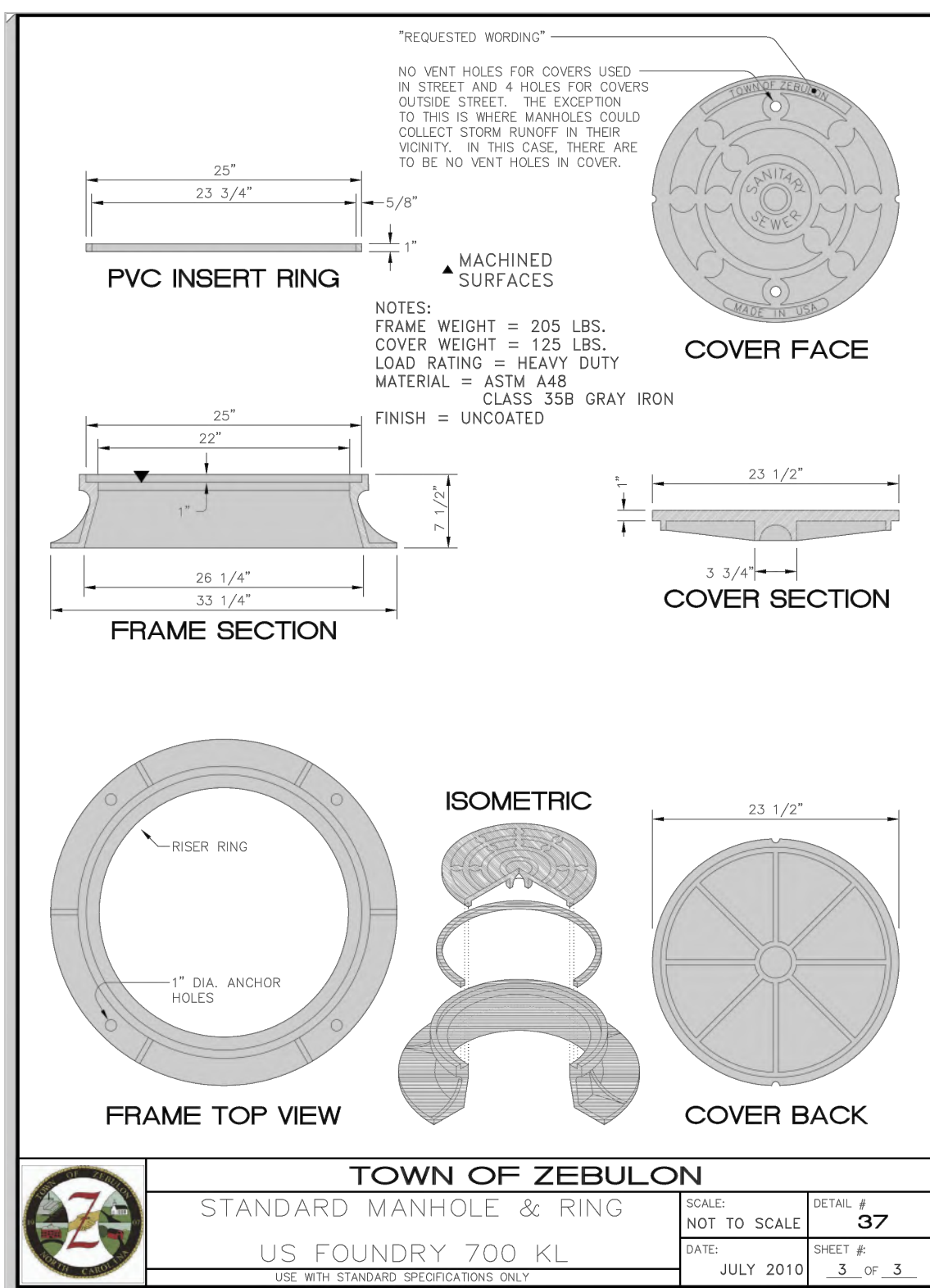
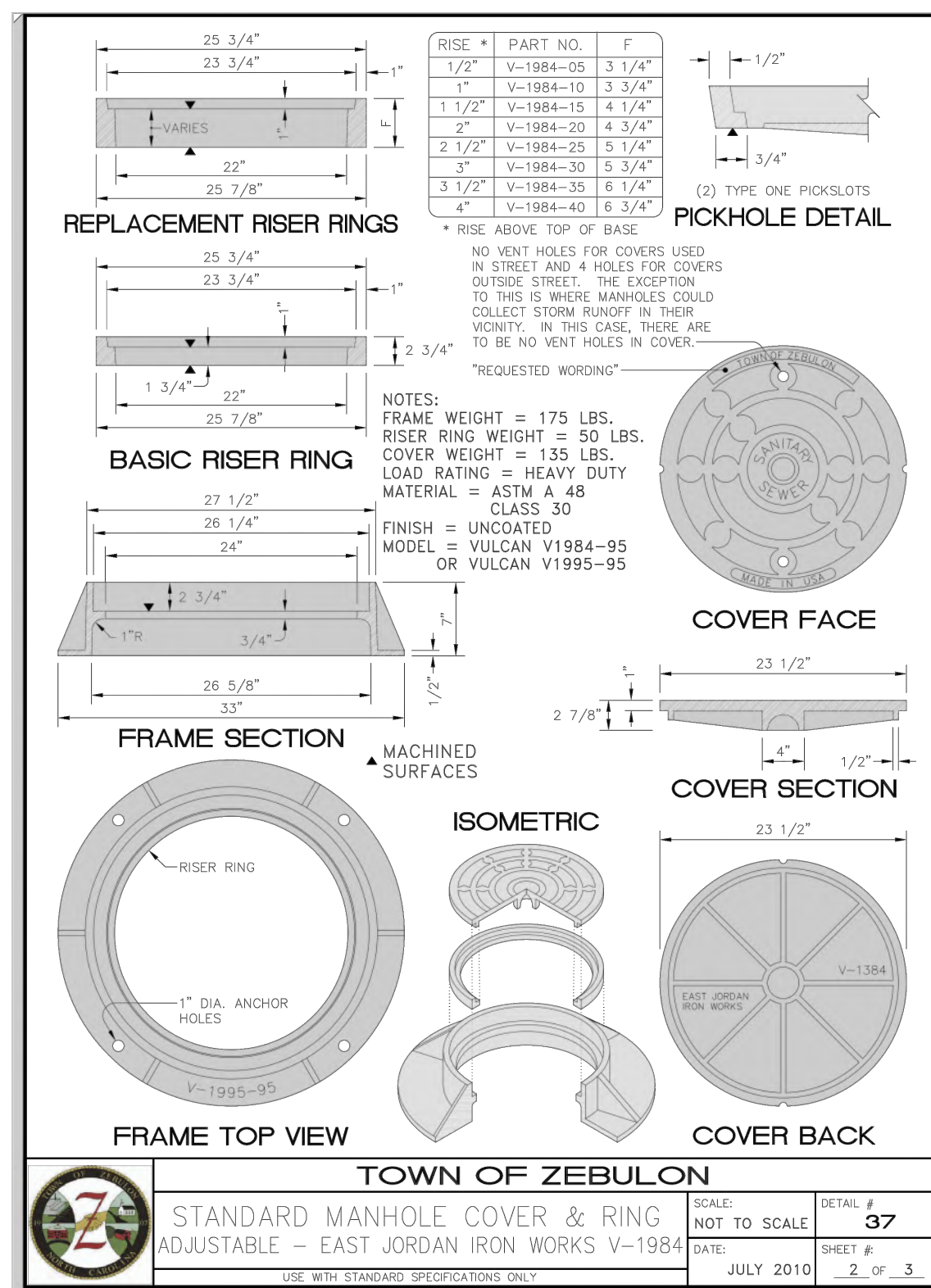

CONSTRUCTION DRAWINGS FOR:
BARBEE ST. SUBDIVISION
 0 E. BARBEE STREET
 ZEBULON, NORTH CAROLINA

Drawn By: **WRR**
 Checked By: **SRN**

DATE: 07 NOV 2022

CONSTRUCTION DRAWING

SITE DETAILS

Job Code: **SCBSZ**

Dwg No. **SITE 705**

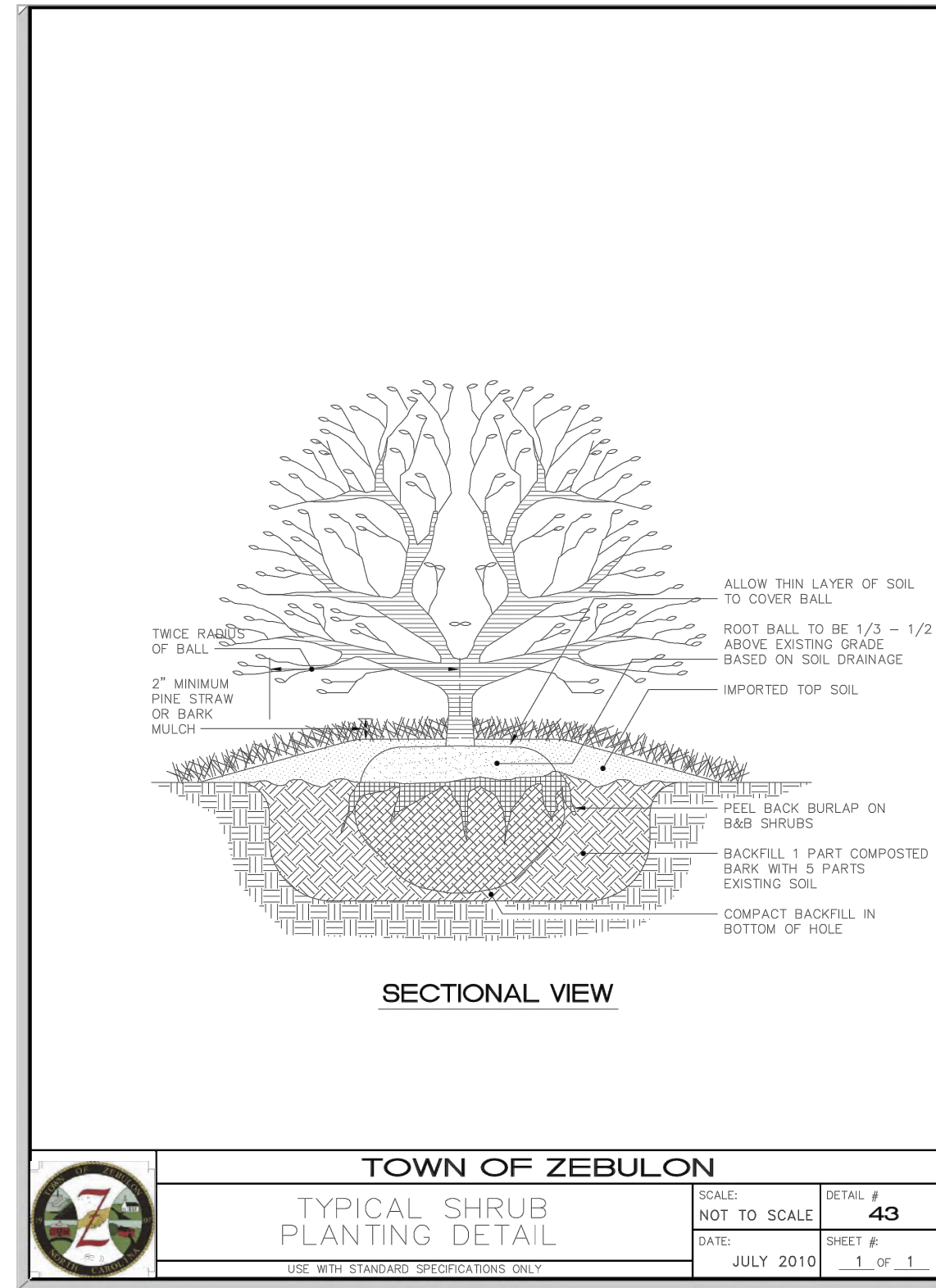

	TOWN OF ZEBULON	
	TYPICAL SHRUB PLANTING DETAIL	DETAIL # 43
	SCALE: NOT TO SCALE	SHEET # 1 OF 1
	DATE: JULY 2010	
<small>USE WITH STANDARD SPECIFICATIONS ONLY</small>		

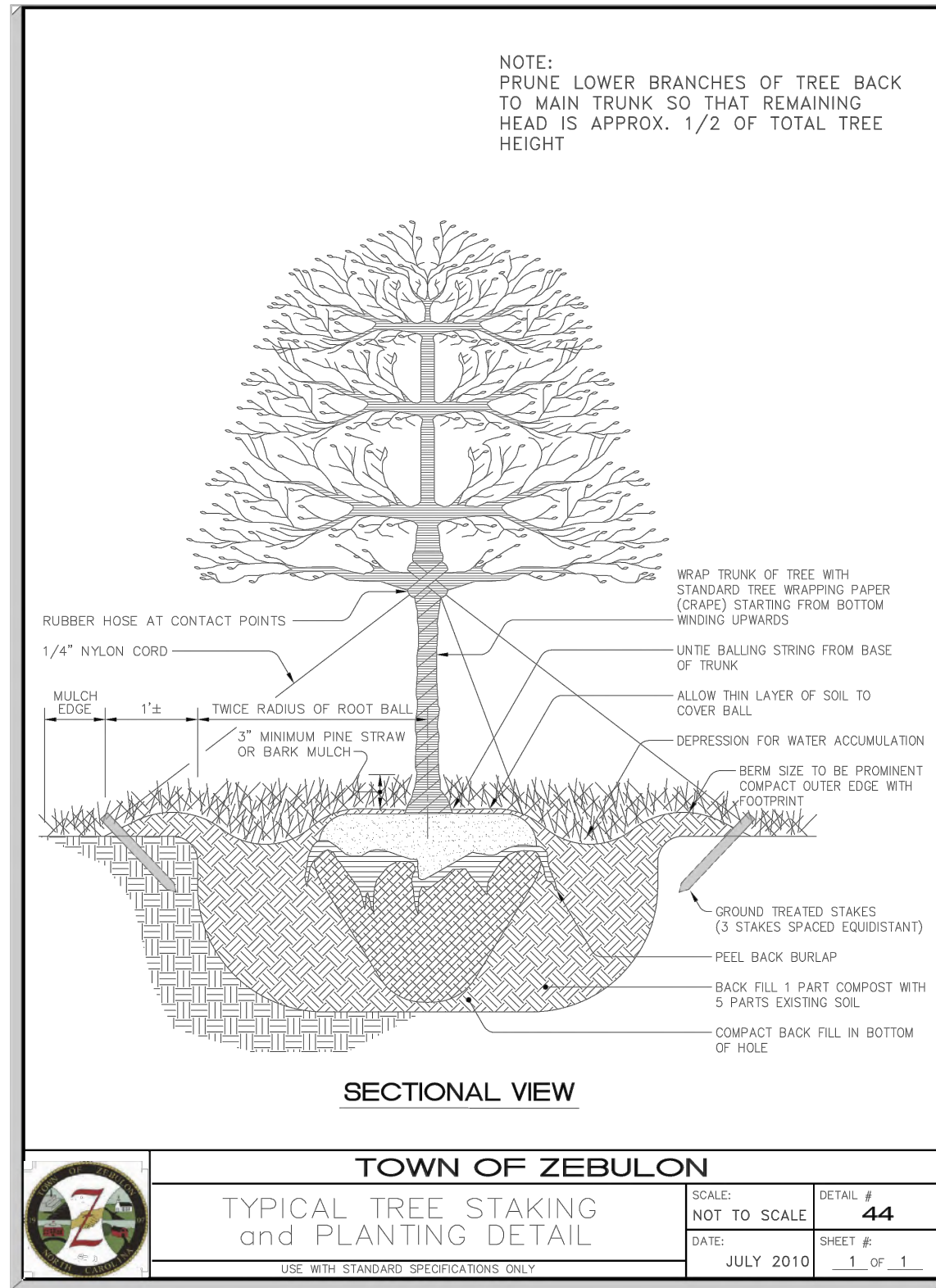

	TOWN OF ZEBULON	
	TYPICAL TREE STAKING and PLANTING DETAIL	DETAIL # 44
	SCALE: NOT TO SCALE	SHEET # 1 OF 1
	DATE: JULY 2010	
<small>USE WITH STANDARD SPECIFICATIONS ONLY</small>		

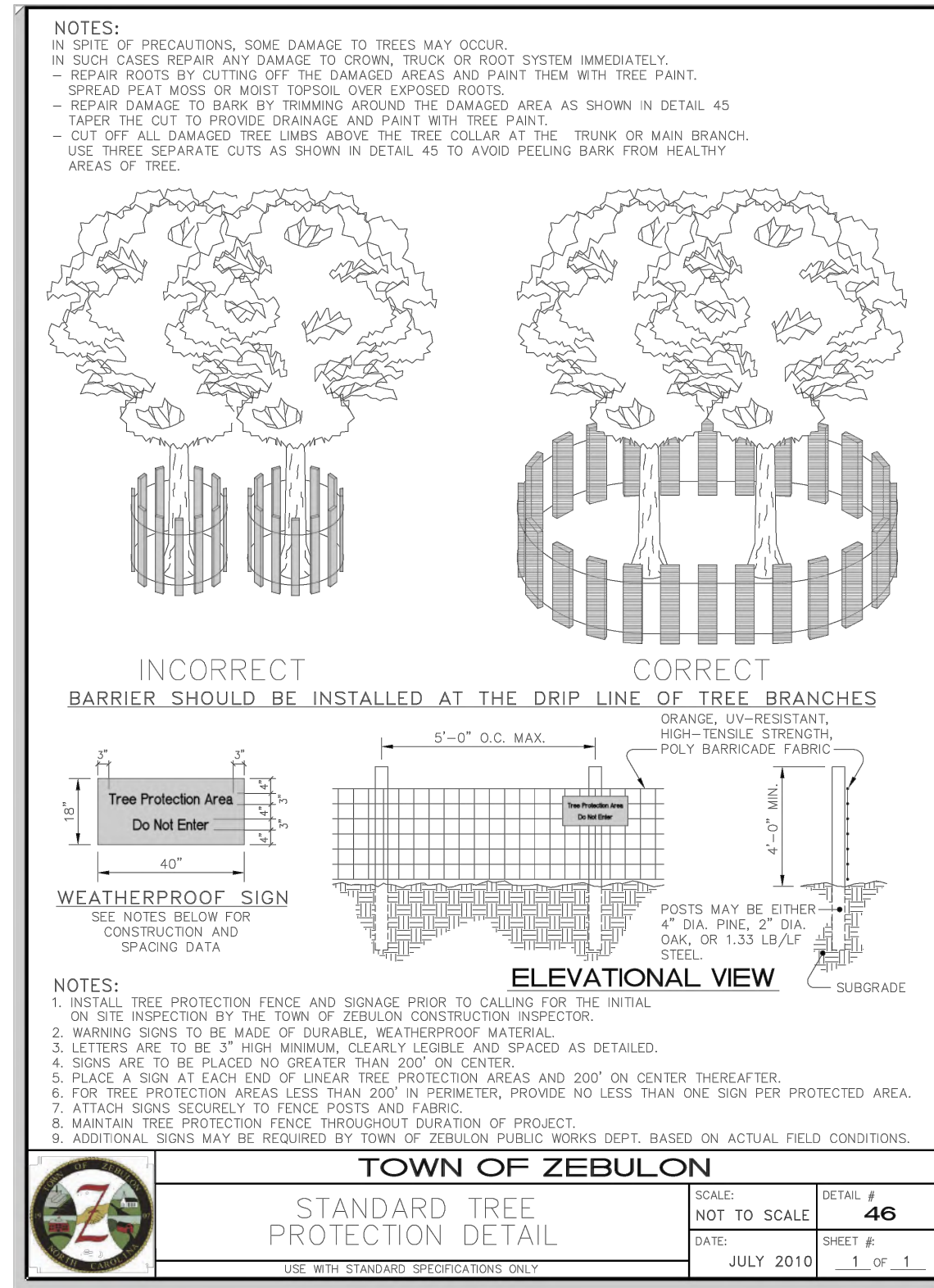

	TOWN OF ZEBULON	
	STANDARD TREE PROTECTION DETAIL	DETAIL # 46
	SCALE: NOT TO SCALE	SHEET # 1 OF 1
	DATE: JULY 2010	
<small>USE WITH STANDARD SPECIFICATIONS ONLY</small>		

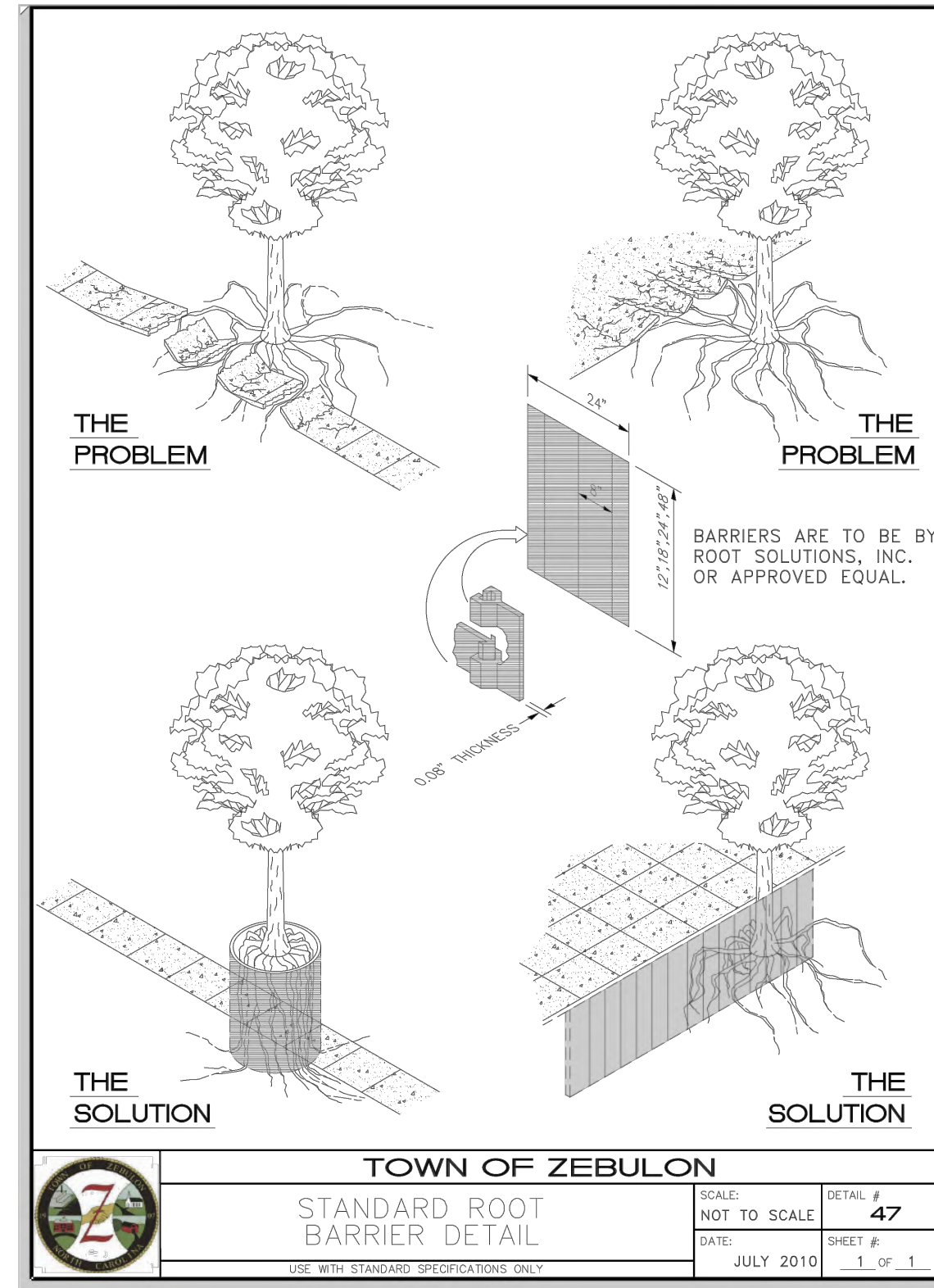

	TOWN OF ZEBULON	
	STANDARD ROOT BARRIER DETAIL	DETAIL # 47
	SCALE: NOT TO SCALE	SHEET # 1 OF 1
	DATE: JULY 2010	
<small>USE WITH STANDARD SPECIFICATIONS ONLY</small>		

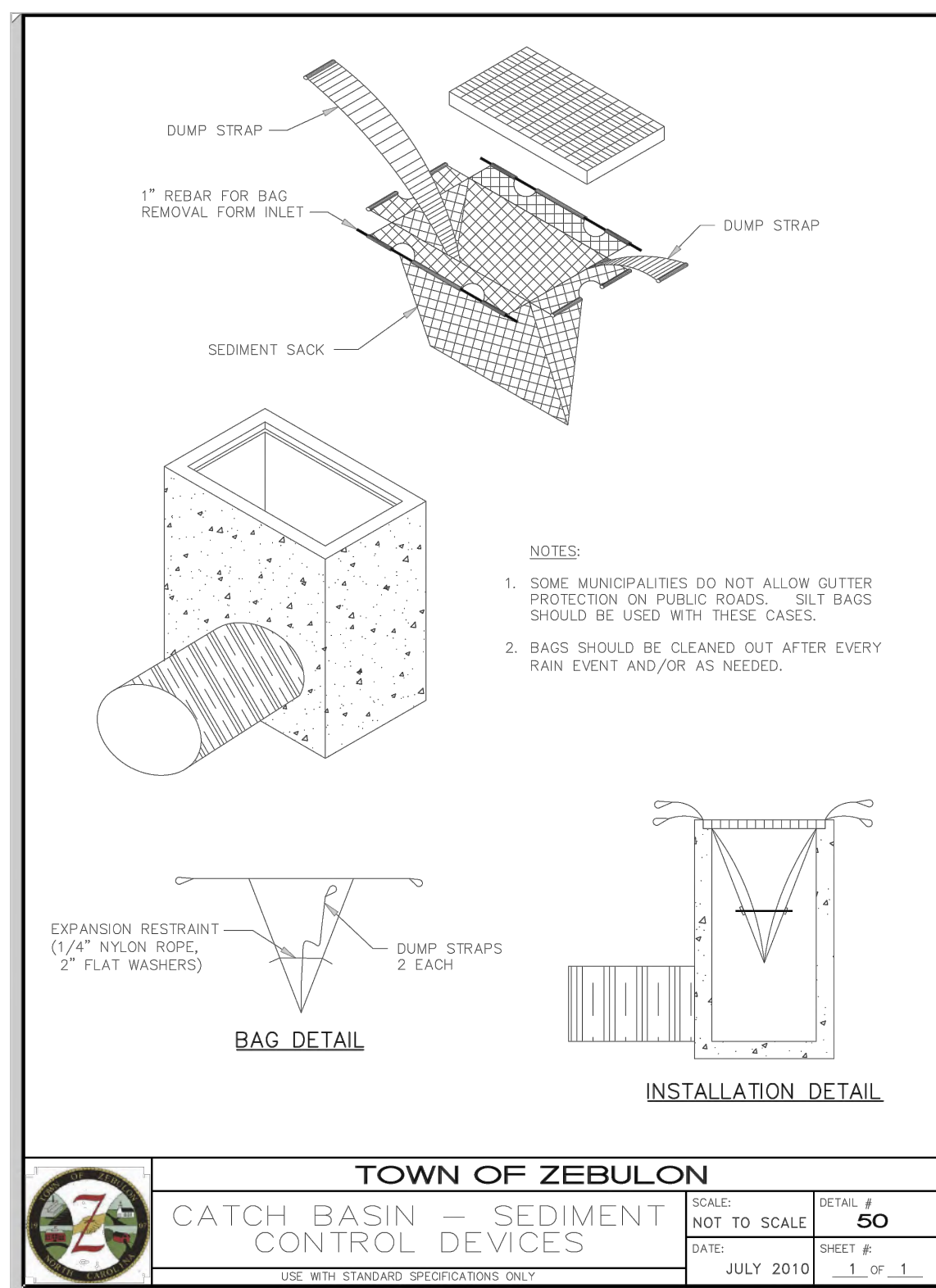

	TOWN OF ZEBULON	
	CATCH BASIN - SEDIMENT CONTROL DEVICES	DETAIL # 50
	SCALE: NOT TO SCALE	SHEET # 1 OF 1
	DATE: JULY 2010	
<small>USE WITH STANDARD SPECIFICATIONS ONLY</small>		

NOTE:
PRUNE LOWER BRANCHES OF TREE BACK TO MAIN TRUNK SO THAT REMAINING HEAD IS APPROX. 1/2 OF TOTAL TREE HEIGHT

NOTES:
IN SPLIT OF PRECAUTIONS, SOME DAMAGE TO TREES MAY OCCUR.
IN SUCH CASES REPAIR ANY DAMAGE TO CROWN, TRUNK OR ROOT SYSTEM IMMEDIATELY.
- REPAIR ROOTS BY CUTTING OFF THE DAMAGED AREAS AND PAINT THEM WITH TREE PAINT.
- SPREAD PEAT MOSS OR MOST TOPSOIL OVER EXPOSED ROOTS.
- REPAIR DAMAGE TO BARK BY TRIMMING AROUND THE DAMAGED AREA AS SHOWN IN DETAIL 45
- TAPER THE CUT TO PROVIDE DRAINAGE AND PAINT WITH TREE PAINT.
- CUT OFF ALL DAMAGED TREE LIMBS ABOVE THE TREE COLLAR AT THE TRUNK OR MAIN BRANCH.
USE THREE SEPARATE CUTS AS SHOWN IN DETAIL 45 TO AVOID PEELING BARK FROM HEALTHY AREAS OF TREE.

NOTES:
1. INSTALL TREE PROTECTION FENCE AND SIGNAGE PRIOR TO CALLING FOR THE INITIAL ON SITE INSPECTION BY THE TOWN OF ZEBULON CONSTRUCTION INSPECTOR.
2. WARNING SIGNS TO BE MADE OF DURABLE, WEATHERPROOF MATERIAL.
3. LETTERS ARE TO BE 3\"/>

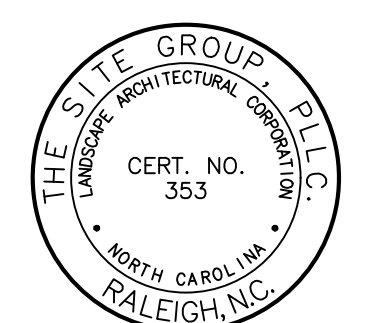

NC ENGINEERING LICENSE NO. P-0803



PRELIMINARY FOR REVIEW ONLY

THE SITE GROUP
CIVIL ENGINEERS • LANDSCAPE ARCHITECTS
THE SITE GROUP, P.L.L.C.
10000 Old NC 27606-1136 USA
Raleigh, NC 919.835.4787
Office: 919.839.2255
E Mail: SRN@thesitegroup.net

CONSTRUCTION DRAWINGS FOR:
BARBEE ST. SUBDIVISION
0 E. BARBEE STREET
ZEBULON, NORTH CAROLINA

Drawn By: **WRR**
Checked By: **SRN**

DATE: 07 NOV 2022

CONSTRUCTION DRAWING

SITE DETAILS

Job Code: **SCBSZ**

Dwg No. **SITE 706**

Copyright © 2022 The Site Group, P.L.L.C. ALL RIGHTS RESERVED

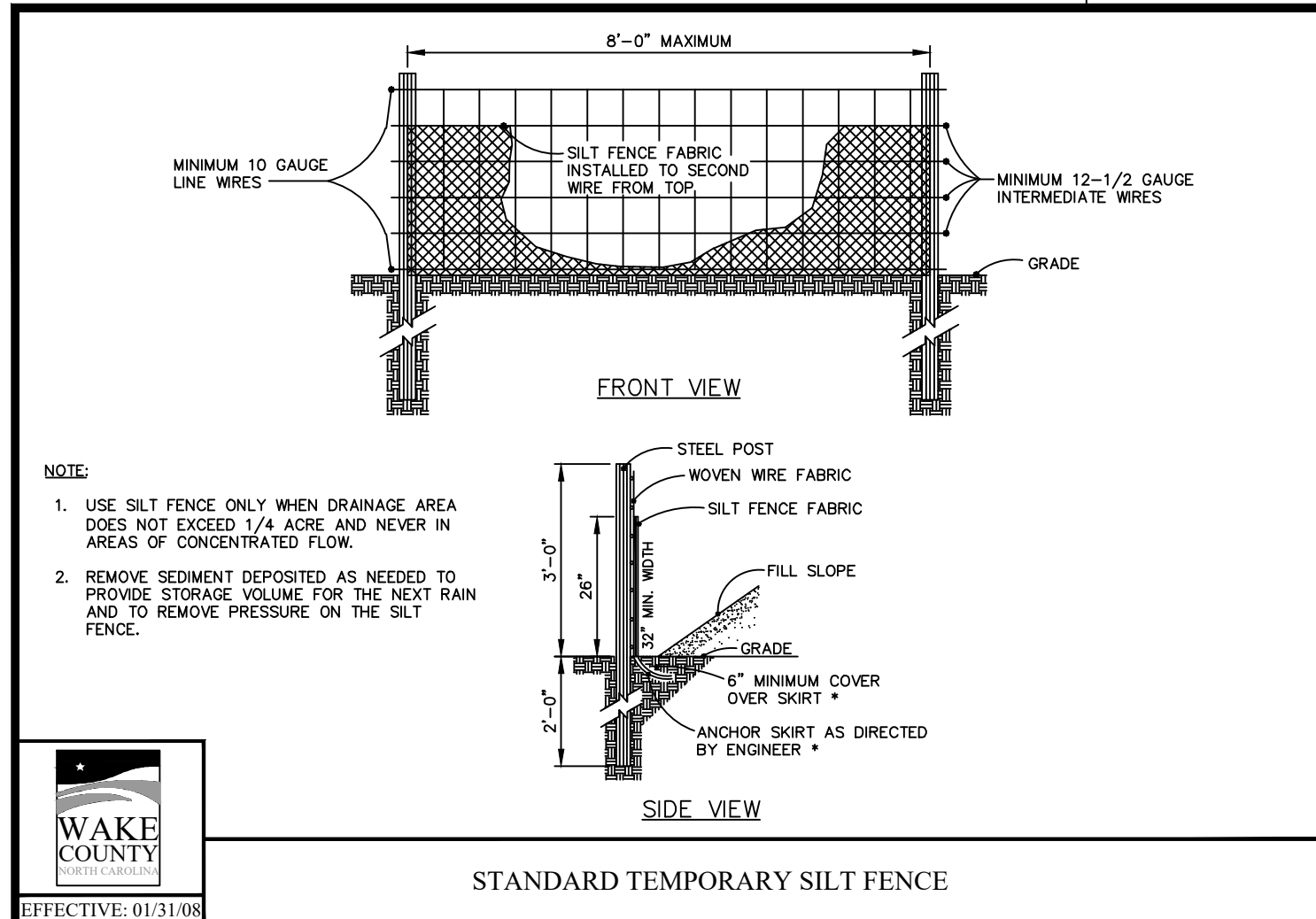

STANDARD TEMPORARY SILT FENCE

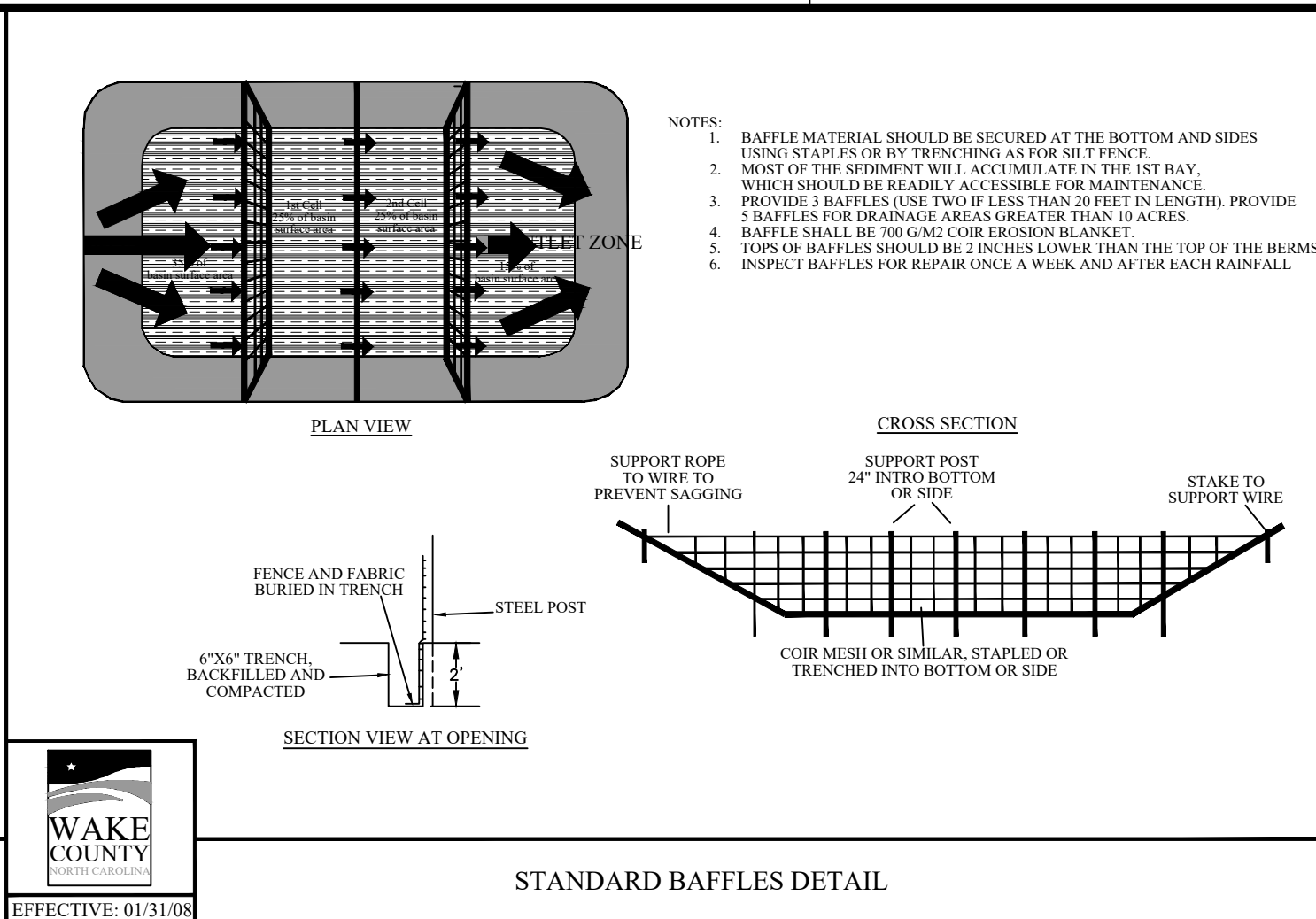

STANDARD BAFFLES DETAIL

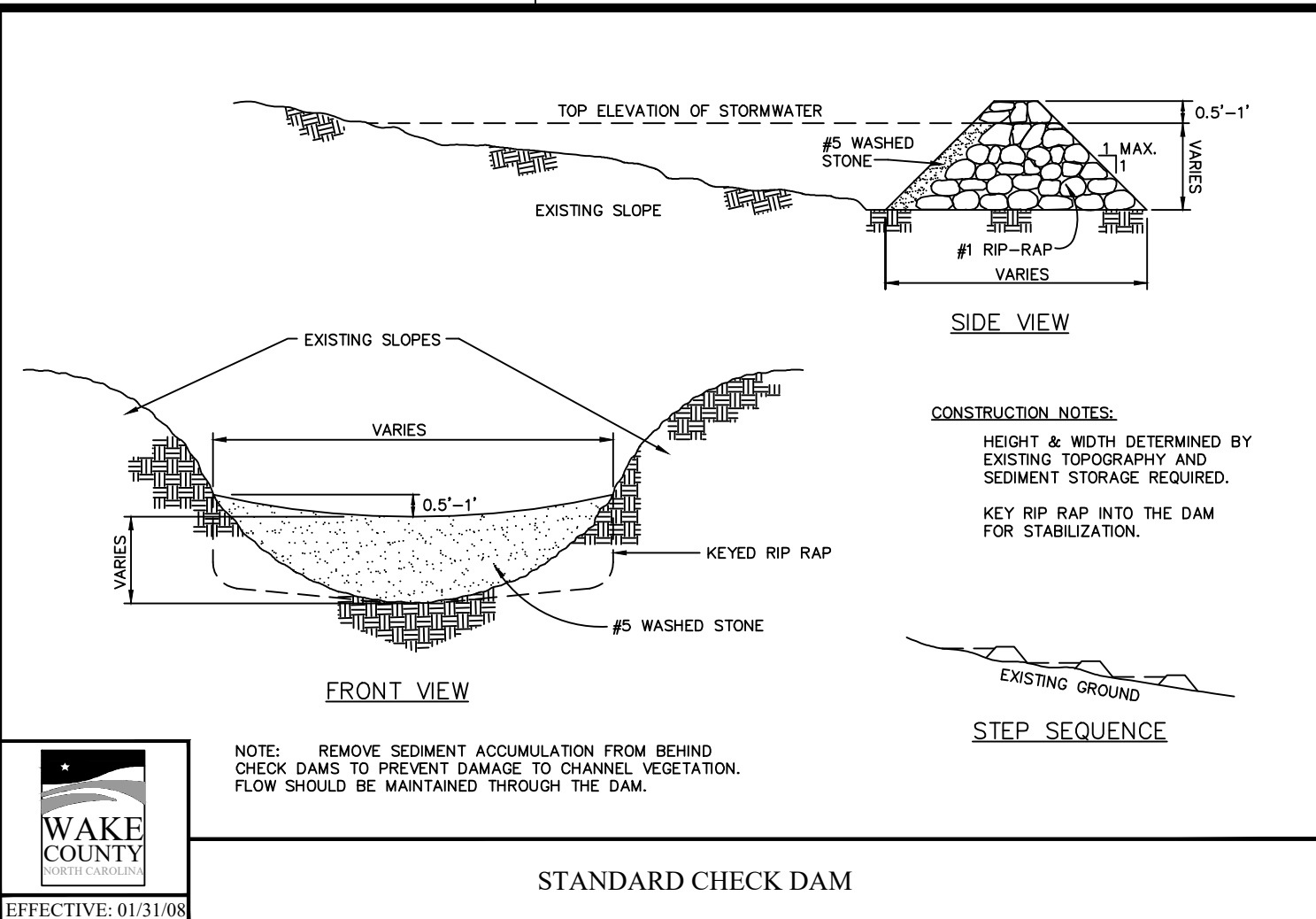

STANDARD CHECK DAM

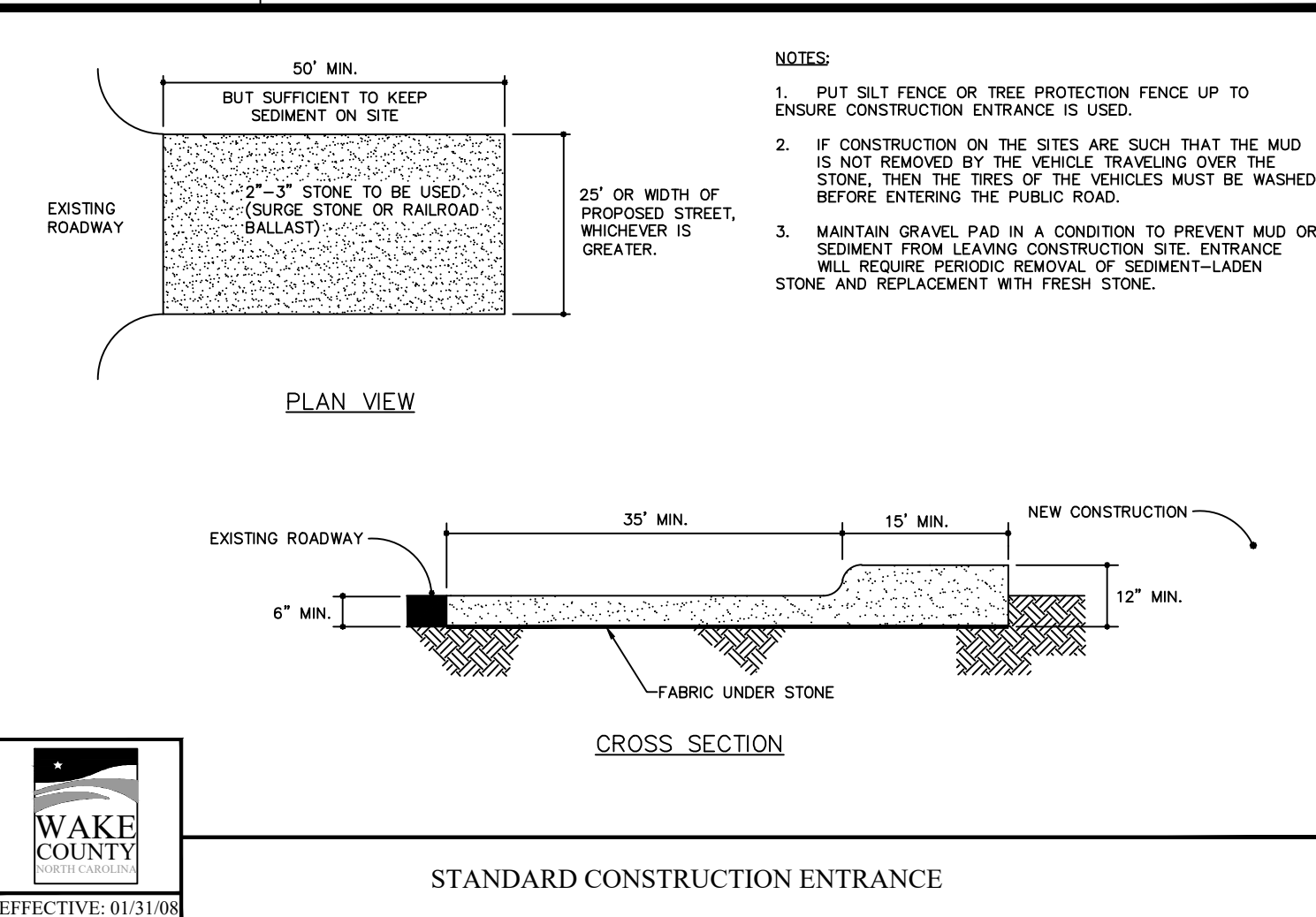

STANDARD CONSTRUCTION ENTRANCE

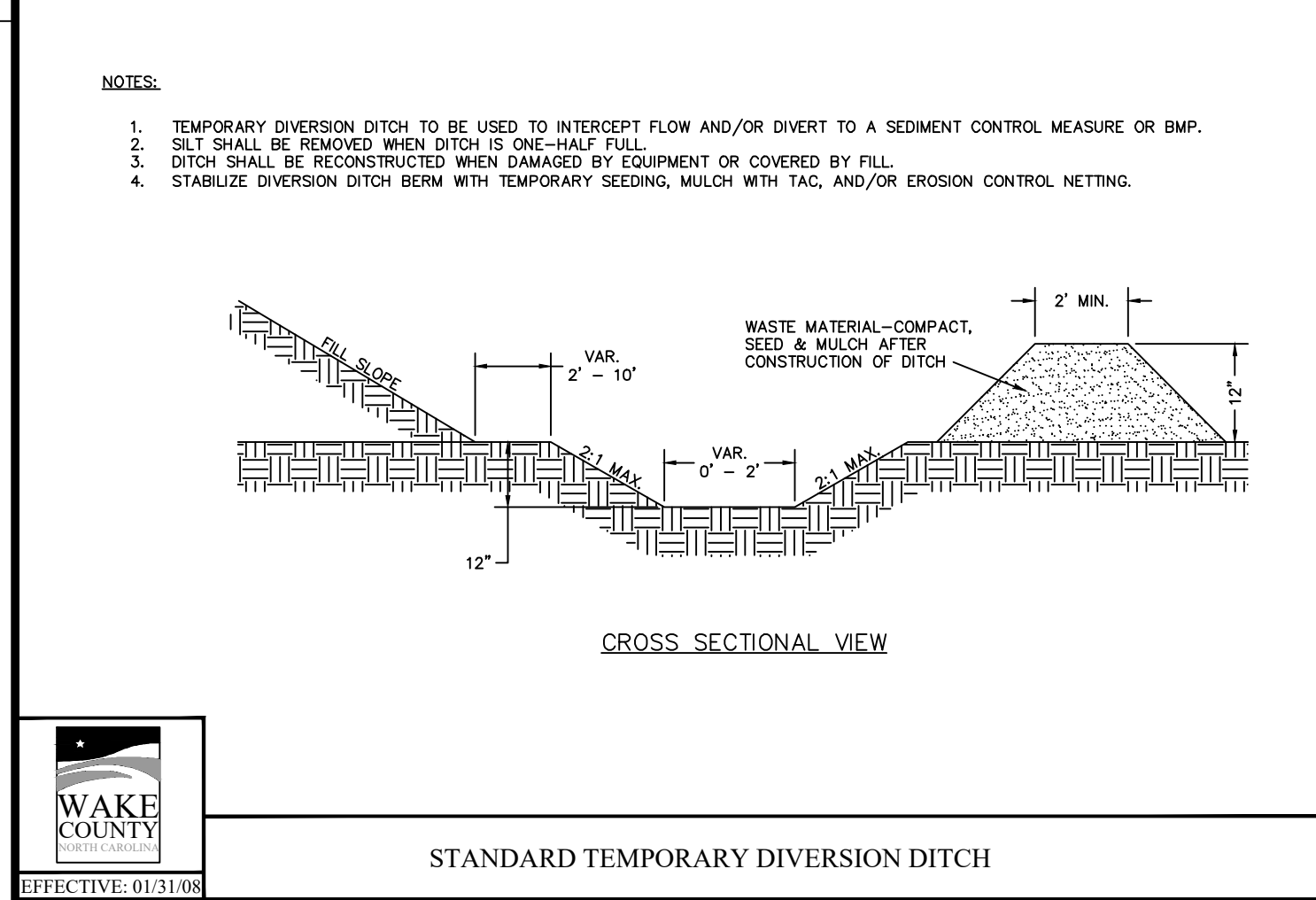

STANDARD TEMPORARY DIVERSION DITCH

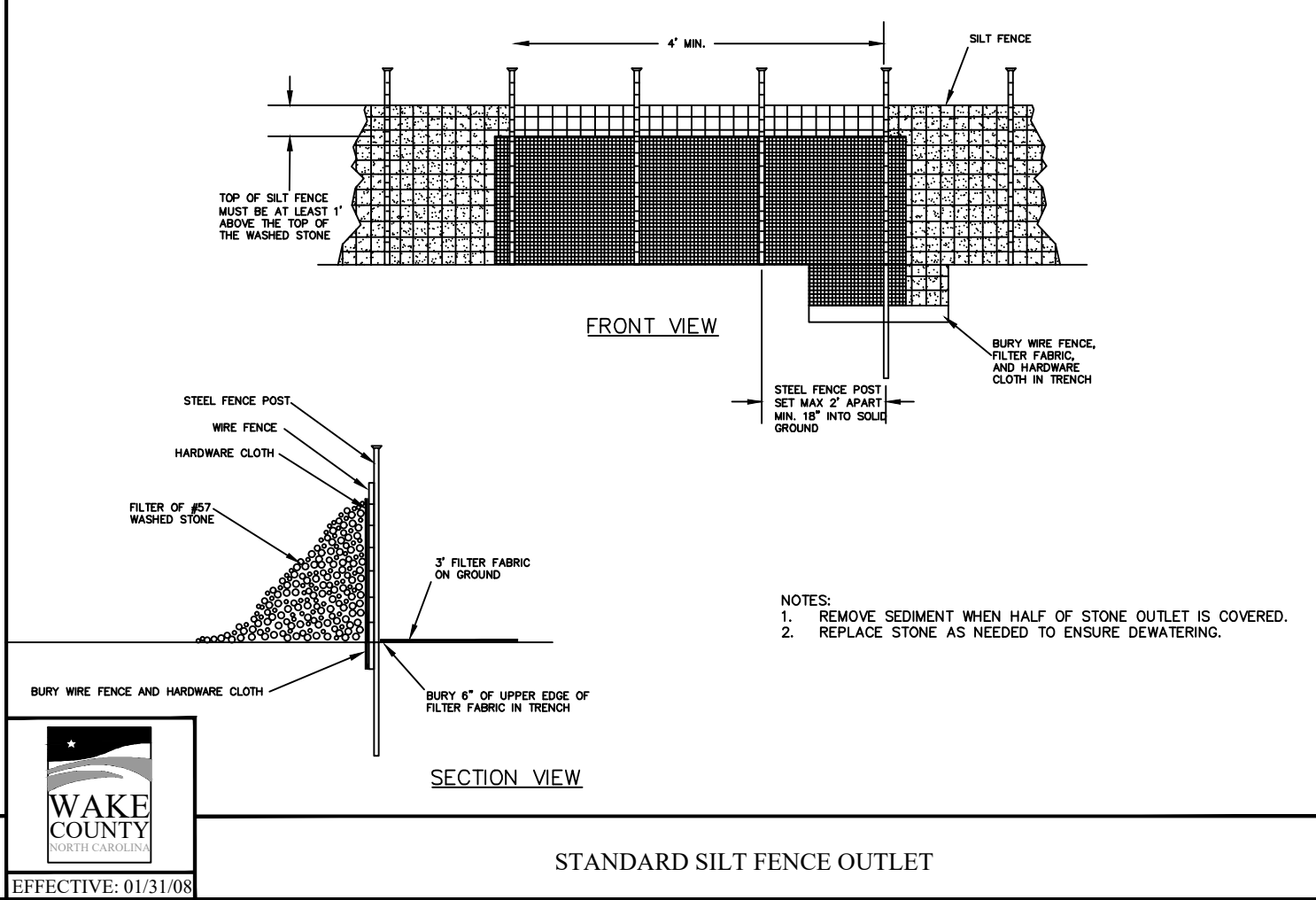

STANDARD SILT FENCE OUTLET

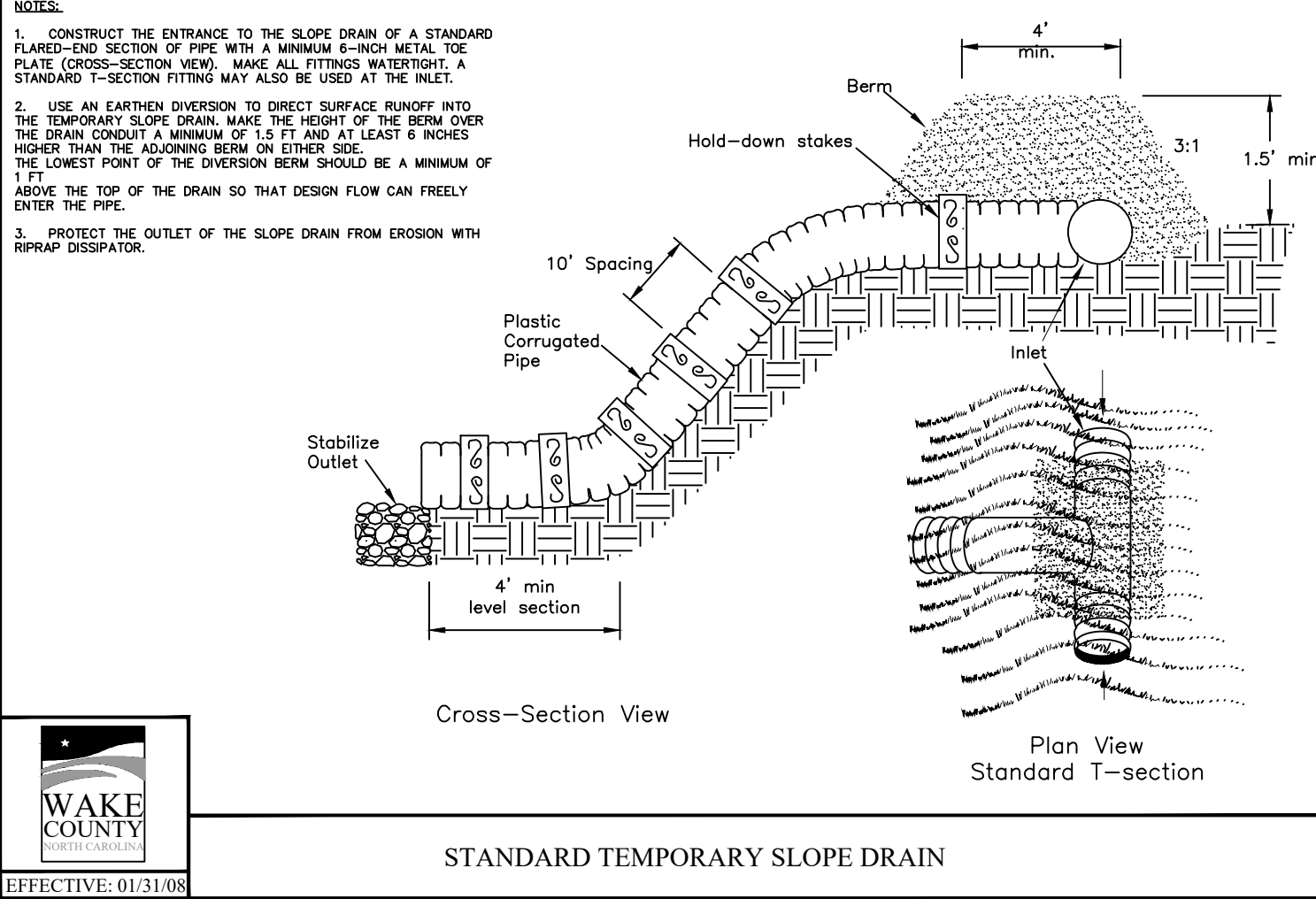

STANDARD TEMPORARY SLOPE DRAIN

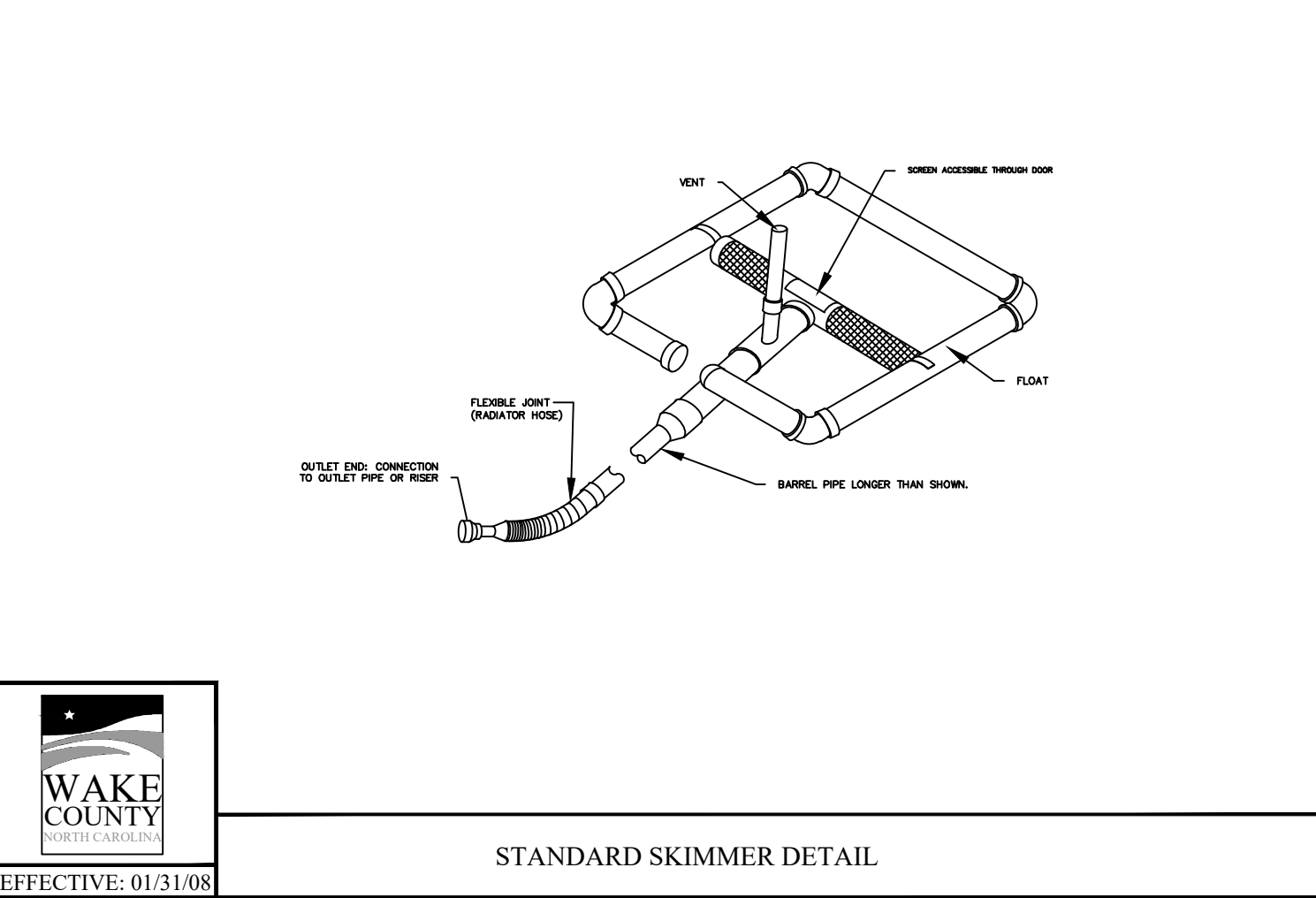

STANDARD SKIMMER DETAIL

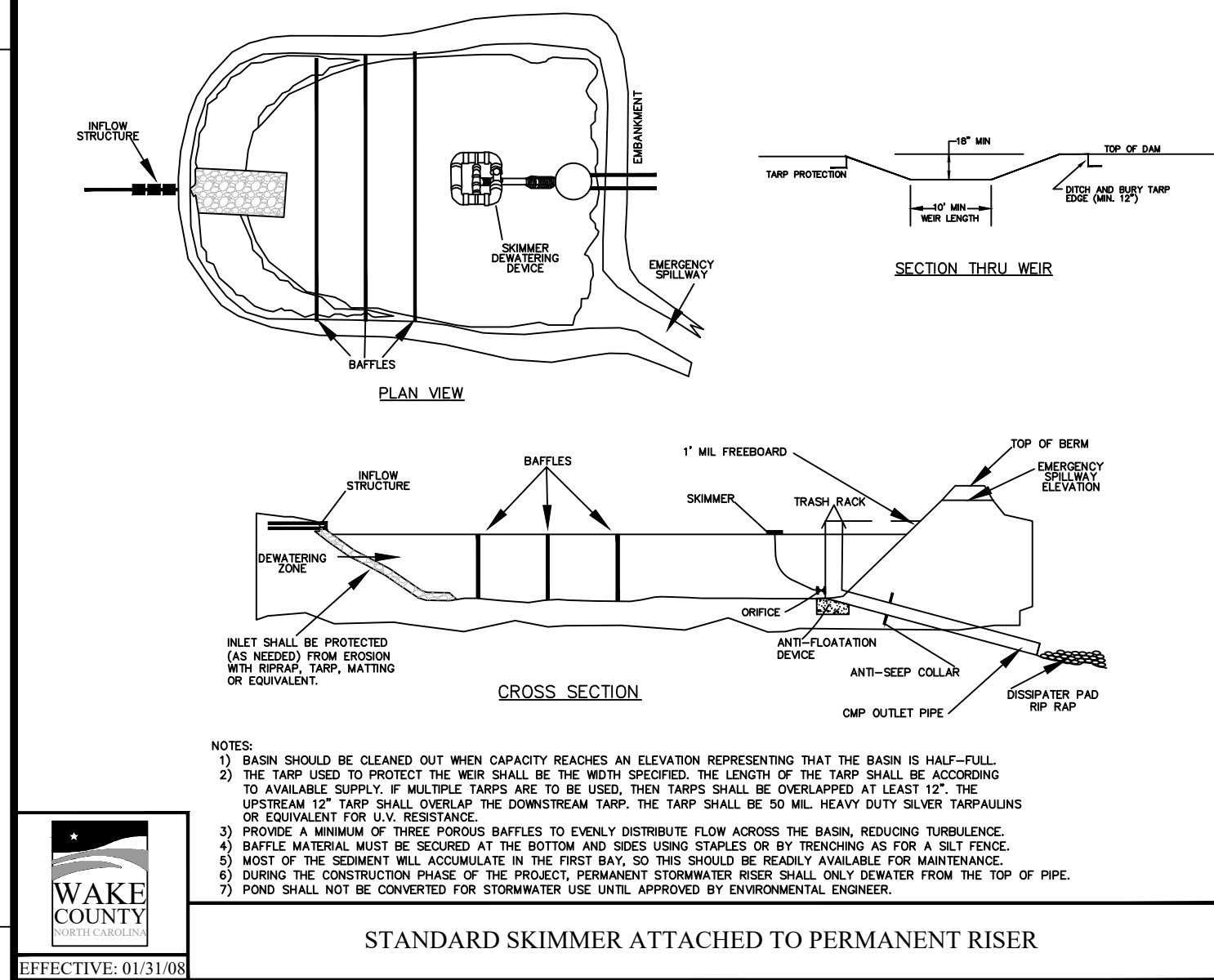

STANDARD SKIMMER ATTACHED TO PERMANENT RISER

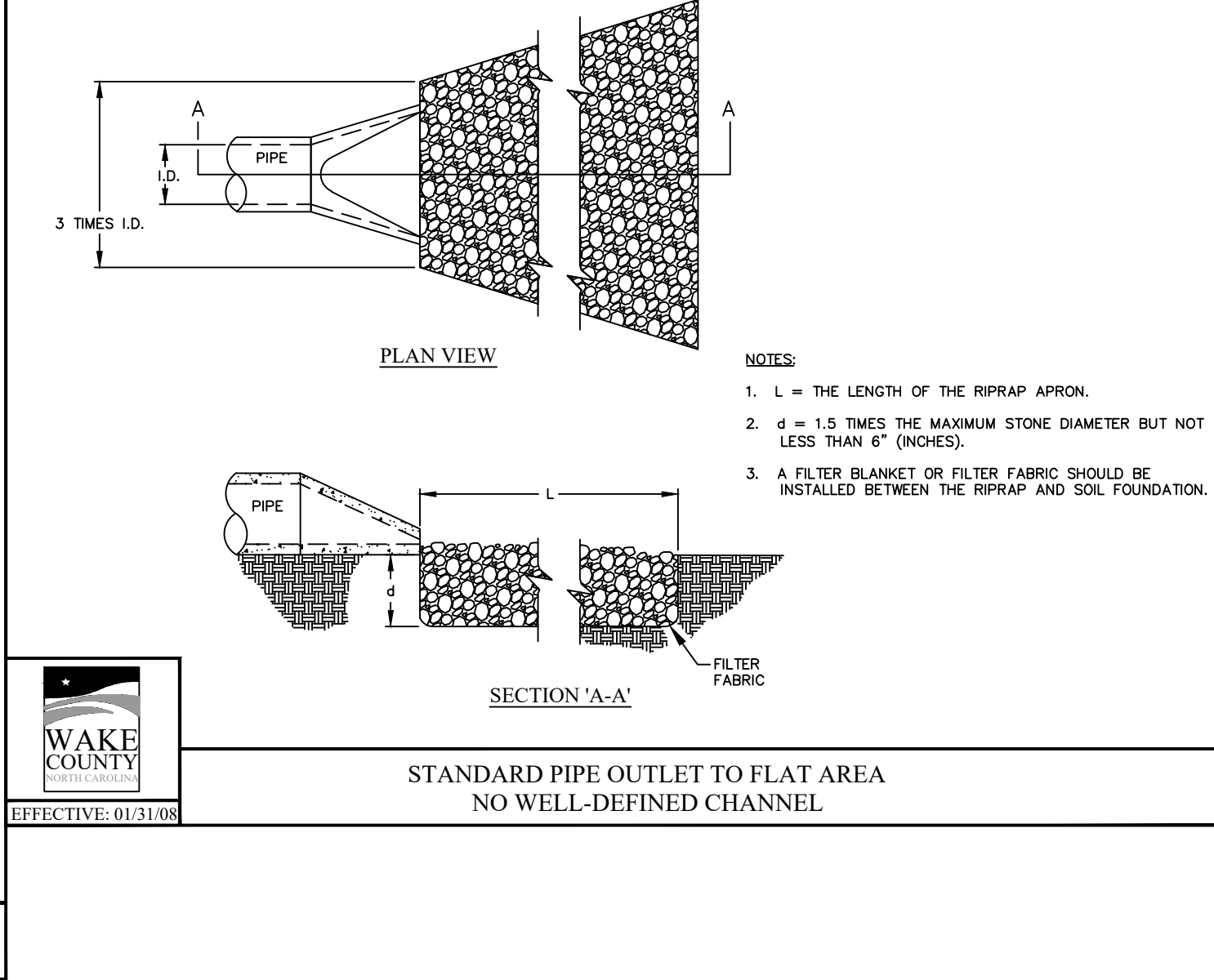

STANDARD PIPE OUTLET TO FLAT AREA NO WELL-DEFINED CHANNEL

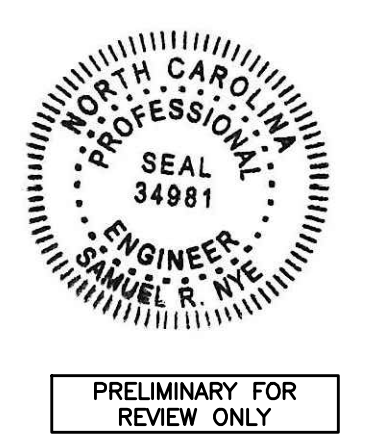
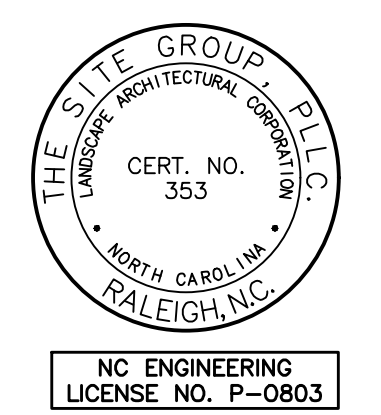

THE SITE GROUP
CIVIL ENGINEERS • LANDSCAPE ARCHITECTS
THE SITE GROUP, PLLC
10100 NC-101
Raleigh, NC 27605-1136 USA
Office: 919.835.4787
Fax: 919.839.2255
E-Mail: SRN@thesitegroup.net

CONSTRUCTION DRAWINGS FOR:
BARBEE ST. SUBDIVISION
0 E. BARBEE STREET
ZEBULON, NORTH CAROLINA

Drawn By: WRR
Checked By: SRN

DATE: 07 NOV 2022

CONSTRUCTION DRAWING

SITE DETAILS

Job Code: SCBSZ

Dwg No. SITE 708